

THERMAL PRINTER
TUP500 SERIES

TECHNICAL MANUAL

[FIRST EDITION]

NOTICE

- All rights reserved. Reproduction of any part of this manual in any form whatsoever, without STAR's express permission is forbidden.
- The contents of this manual are subject to change without notice.
- All efforts have been made to ensure the accuracy of the contents of this manual at the time of going to press. However, should any errors be detected, STAR would greatly appreciate being informed of them.
- The above notwithstanding, STAR can assume no responsibility for any errors in this manual.

INTRODUCTION

This manual describes the thermal printer TUP500 series.

It is designed for use as a reference for periodic inspections and maintenance procedures to be executed by service personnel. It is not intended for the general user. Users of this manual should have a basic knowledge and understanding of the English language.

● This manual is divided into the following sections:

Chapter 1 Adjustments

Chapter 2 Maintenance and Lubrication

Chapter 3 Parts List

● First edition : Feb. 2009

CHAPTER 1

ADJUSTMENTS

This printer has undergone various adjustments so that it will attain a given standard of performance. In this chapter, a brief explanation is given of the methods for making adjustments. Follow the instructions when performing maintenance inspections or when replacing parts to correct malfunctions.

1. Sensor Adjustment	2
1.1 Adjustment of the PE/BM Sensor	2
1.2 Adjustment of the NE Sensor	4
1.3 Adjustment of the Presenter Sensor	5

1. Sensor Adjustment

This printer is equipped with the following three paper sensors:

- PE(Paper End)/BM(Black Mark) Sensor
Detects presence of roll paper and black marks.
- NE(Near End) Sensor
Detects whether the roll paper is nearing its end.
- Presenter Sensor (TUP592 Only)
Detects paper in presenter.

The aforementioned sensors can be adjusted as follows.

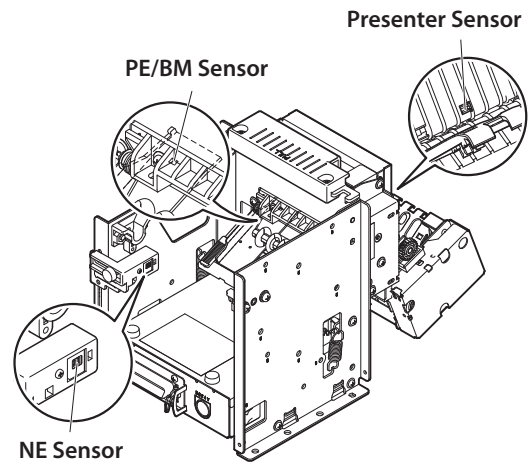

1.1 Adjustment of the PE/BM Sensor

1. Turn the printer off and unplug the power cord.
2. Remove the screws. Then, remove the board chassis.
3. Using the tip of a ballpoint pen or a similar object, set the DIP switches as follows: DSW1-4 OFF, DSW1-5 ON.

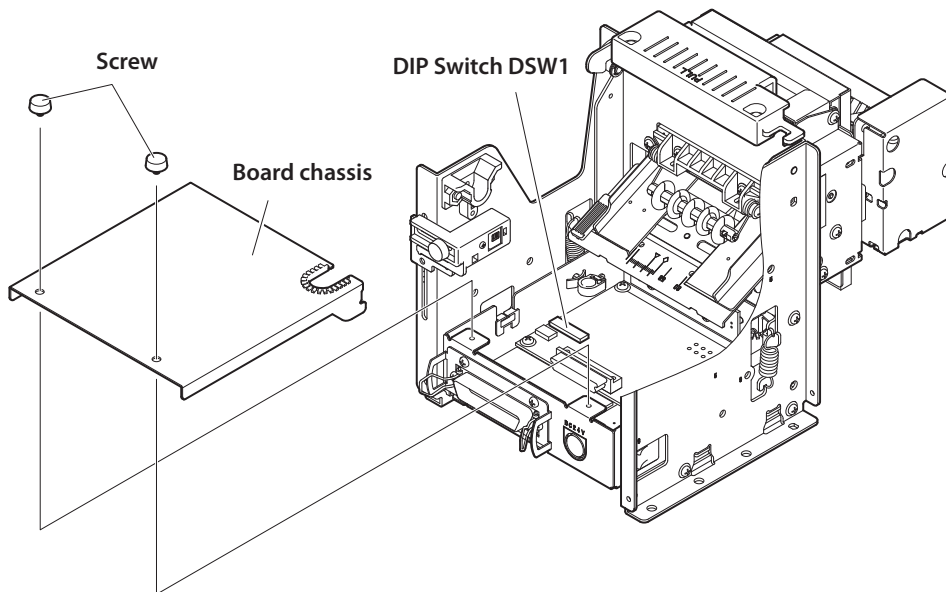

4. Set ordinary paper that is not used for black marks, in the PE/BM sensor unit shown below.
Use the release lever to open the platen unit (the TUP592 includes presenter unit), insert the paper from the paper insertion inlet and then close the platen unit to set the paper.

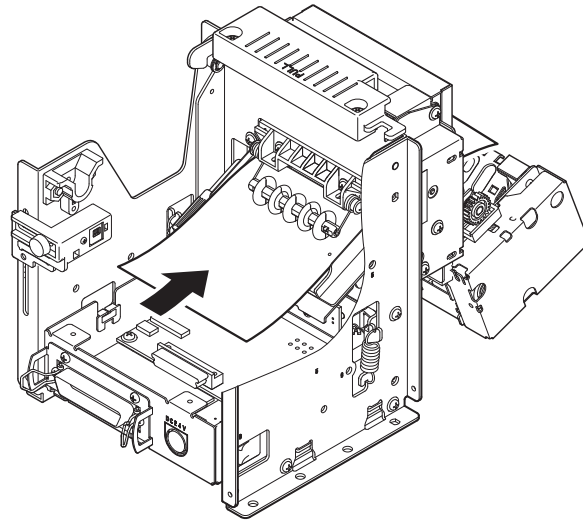

5. Turn the power on. The LED on the control panel will flash two times, then the printer will enter the PE/BM sensor adjustment mode.
6. Use a small regular screwdriver to slowly turn the VR1 clockwise, as shown in the drawing below. Adjust this to a position where both LED1 (green) and LED2 (red) light.
7. Turn the power OFF.
8. Turn the DIP switch DSW 1-4 and DSW 1-5 to its original setting.

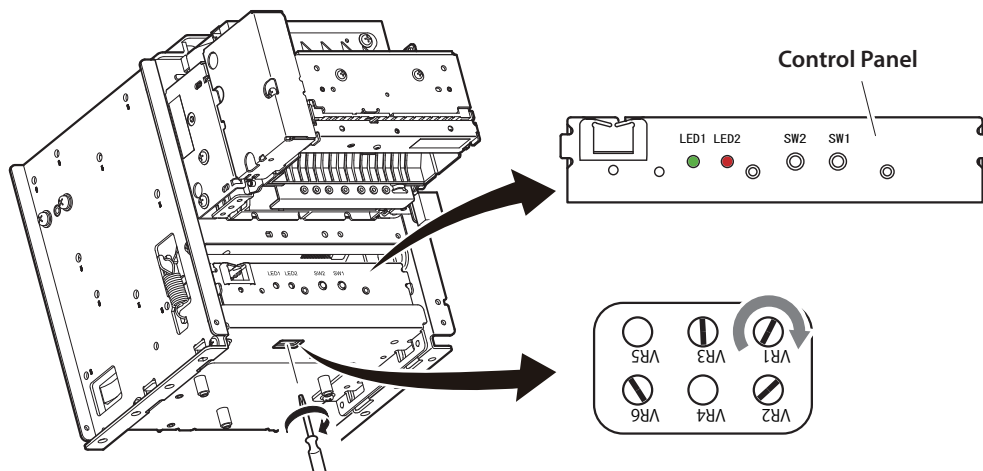

This completes the PE/BM sensor adjustment.

1.2 Adjustment of the NE Sensor (TUP592 Only)

1. Turn the printer off and unplug the power cord.
2. Remove the screws. Then, remove the board chassis.
3. Using the tip of a ballpoint pen or a similar object, set the DIP switches as follows: DSW1-4 OFF, DSW1-5 ON.

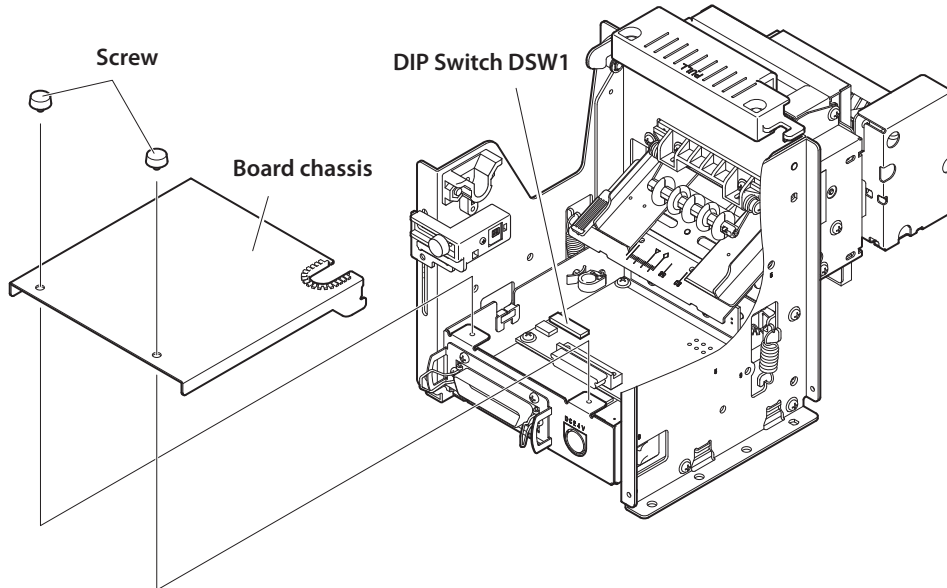

4. Set unused roll paper that will actually be use.
5. Connect the AC adapter and turn the power switch on while pressing switch SW2 on the control panel. The LED on the control panel will flash two times, then the printer will enter the NE sensor adjustment mode.
6. Use a small regular screwdriver to slowly turn the VR6 clockwise, as shown in the drawing below. Adjust this to a position where both LED1 (green) and LED2 (red) light. If it is not possible to adjust to a position where both LED1 (green) and LED2 (red) light, adjust to a position where LED1 (green) is extinguished and LED2 (red) is lit.

Note: When tilting the unit, be careful that the paper does not fall out.

7. Turn the power OFF. Turn the DIP switch DSW 1-4 and DSW 1-5 to its original setting.

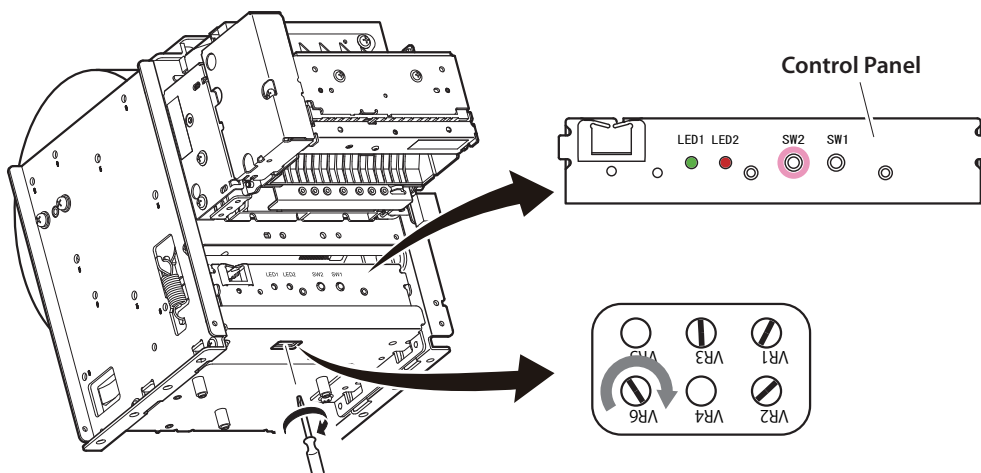

This completes the NE sensor adjustment.

1.3 Adjustment of the Presenter Sensor

1. Turn the printer off and unplug the power cord.
2. Remove the screws. Then, remove the board chassis.
3. Using the tip of a ballpoint pen or a similar object, set the DIP switches as follows: DSW1-4 OFF, DSW1-5 ON.

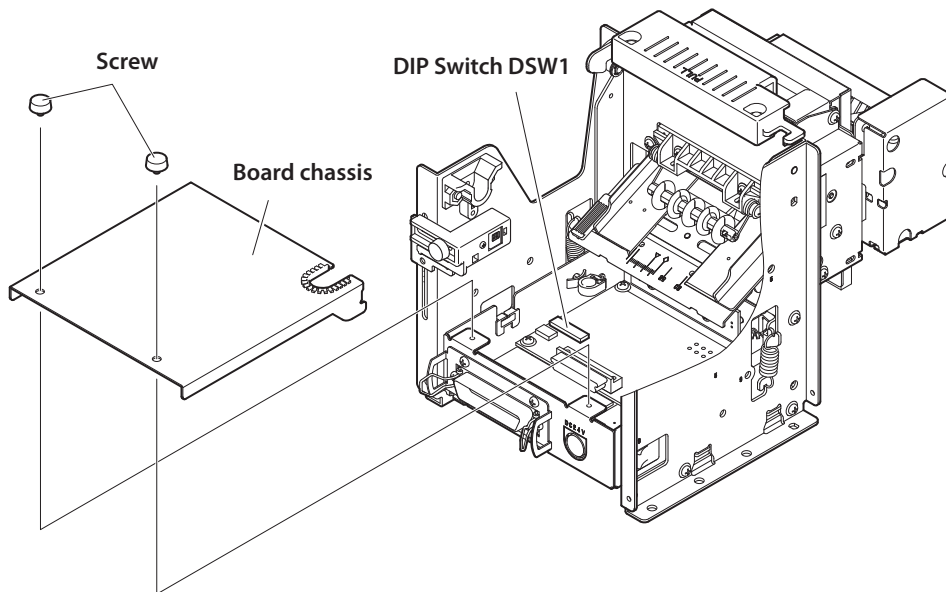

4. Set paper into the presenter portion as shown below.
Lift the paper holder and insert the paper. Rotate the knob toward yourself to set the paper perfectly straight.

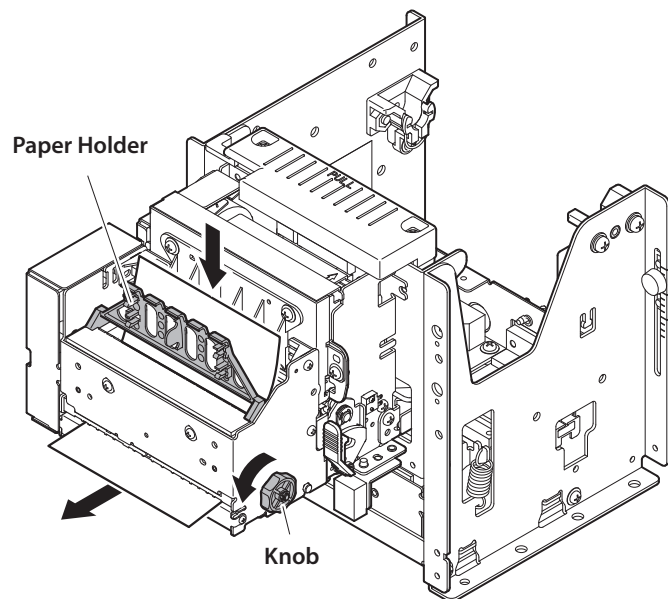

5. Connect the AC adapter and turn the power switch on while pressing switch SW1 on the control panel. The LED on the control panel will flash two times, then the printer will enter the presenter sensor adjustment mode.
6. Use a small regular screwdriver to slowly turn the VR3 clockwise, as shown in the drawing below. Adjust this to a position where both LED1 (green) and LED2 (red) light.
If the position where both LED1 (green) and LED2 (red) light, turn VR3 clockwise slowly to adjust to a position where both LED1 (green) and LED2 (red) light.

Note: 1) When adjusting, always rotate clockwise.

If rotated in the other direction, accurate adjustment is not possible.

2) Each time the printer enters the presenter paper detection sensor adjustment mode, this adjustment is necessary.

3) There is a point where the LED flashes instantly. That is not an adjustment position.
There is a point where the LED lights completely. That is the adjustment position.

7. Turn the power OFF. Turn the DIP switch DSW 1-4 and DSW 1-5 to its original setting.

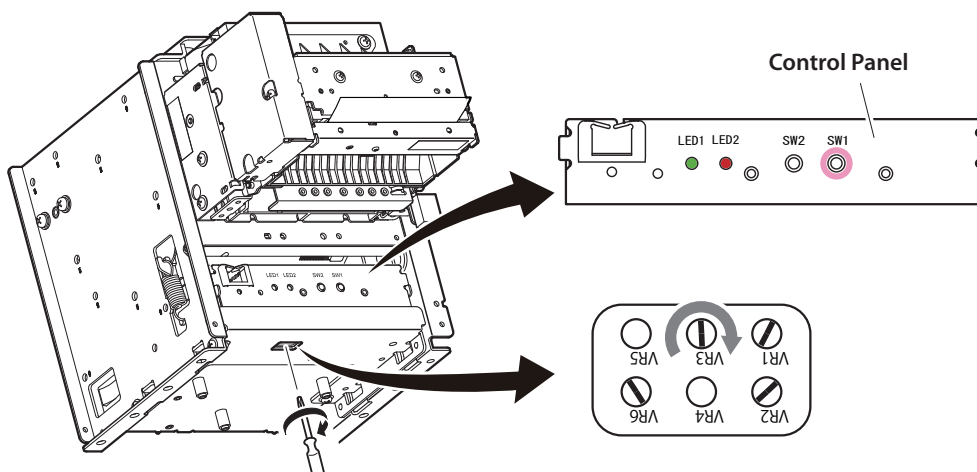

This completes the Presenter sensor adjustment.

CHAPTER 2

MAINTENANCE AND LUBRICATION

1. Maintenance	8
1-1. Cleaning the Thermal Head and Platen	8
1-2. Handling Paper Jams	9
1-3. How to Release the Cutter Lock	9
2. Lubrication	10
2-1. Lubricant	10
2-2. Lubricating Method	10
2-3. Lubricated Areas	10

1. Maintenance

In order to maintain the optimum performance of this printer and to prevent trouble, maintenance must be carried out according to the following items.

When performing maintenance, always turn off the power, and take the appropriate measures to prevent static electricity.

1-1. Periodic Maintenance

To ensure long-term and stable printing, periodically clean the modules. It is recommended that you clean every 3 months or every 500,000 lines.

The thermal head and platen can be cleaned by opening the platen unit (including the presenter unit of TUP592) with the release lever.

- **Thermal Head Cleaning Method**

To clean the thermal head heating elements, wipe with a cotton swab dampened with an alcohol based cleaner (such as ethanol or methanol). Also, do not apply excessive force when doing so. Wipe the heating elements gently. After cleaning, check that the alcohol has completely evaporated before closing the platen unit.

- **Platen Cleaning Method**

Dampen a soft cloth with an alcohol-based solvent (such as ethanol or methanol) and wipe the platen while slowly turning it. Also, completely wipe away all of the paper dust on the rubber platen. If the cleaning is incomplete, there may be problems in paper feeds.

- **Presenter Sensor and Peripheral Maintenance Method (only TUP592)**

Remove any dirt, dust, or paper cuttings that may be adhering to the presenter sensor or the vicinity. Use a soft, dry cotton cloth, swab or brush to clean. Also, do not apply excessive force when doing so.

- **PF Roller Cleaning Method (only TUP592)**

To clean the PF roller, dampen a soft cloth with an alcohol-based solvent (such as ethanol or methanol) and clean the PF roller while slowly turning it using the knob. Also, do not apply excessive force when doing so. Wipe the heating elements gently.

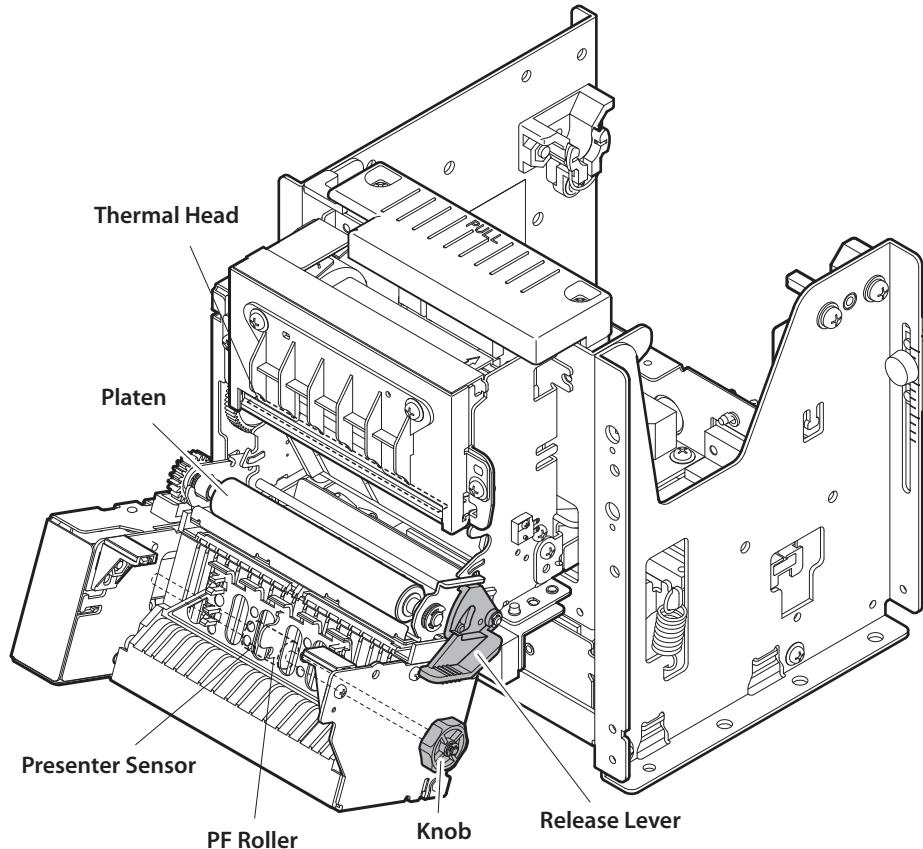

Fig. 2-1 Locations to Perform Periodic Maintenance (TUP592 External View)

1-2.Handling Paper Jams

If recording paper should become jammed, open the platen unit (including the presenter unit of TUP592) and remove the jammed paper. Never pull on the jammed paper unnecessary while the printer unit is closed because this can damage the drive system parts.

Remove jammed paper according to the following procedures.

1. Open the platen unit using the release lever.
2. Rotate the knob to remove the jammed paper.
3. Close the platen unit. Check that it has been completely closed at this time.

Notes: 1) When removing the jammed paper, never move you hands near the tear bar or the auto-cutter because it is very dangerous. Also, when opening or closing the rotating portions, be careful not to get your hands or fingers caught.

- 2) **When locking the cutter blades, do not forcefully rotate the platen unit (including the presenter unit of TUP592) because this can be the cause of machine failure. See the following item 1-3 for releasing the cutter lock and opening the platen unit.**

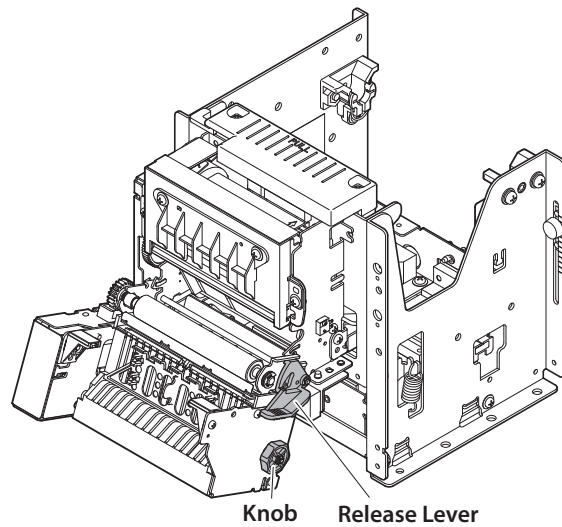

Fig. 2-2 Handling Paper Jams (TUP592 External View)

1-3.How to Release the Cutter Lock

Use the following procedures to release the auto-cutter lock if trouble occurs, such as when paper becomes chewed.

1. Turn the apparatus power off.
2. Rotate the emergency knobs in the direction of the arrows on the top of the auto-cutter unit case to return the cutter blades to their home position. The emergency knob should be rotated using a tweezers, screwdriver or ball-point pen to prevent accidents.

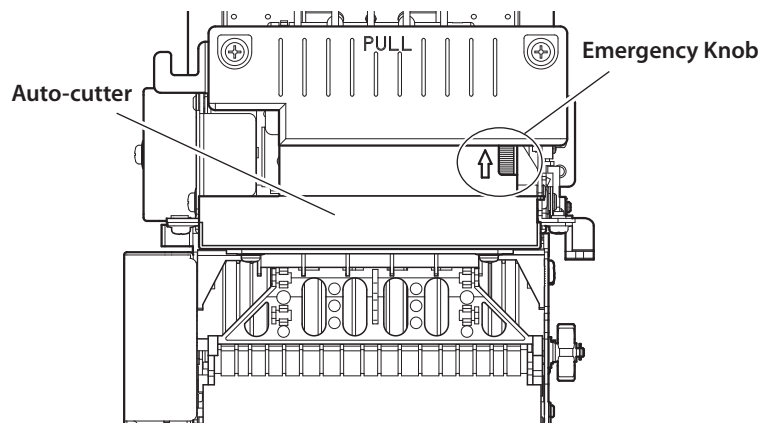

Fig. 2-3 Handling The Cutter Lock (TUP592 External View)

2. Lubrication

Lubrication is very important to maintain optimum performance and to prevent trouble.

2-1.Lubricant

The type of lubricant greatly affects the performance and durability of the printer, especially in a low temperature environment. We recommend use of the grease listed below for this printer.

Type of oil	Product name	Maker
Grease	Molykote EM-30L	Dow Corning Corporation
Oil	Mobil 1	Mobil Oil Co., Ltd.

2-2.Lubricating Method

When lubrication is carried out in assembly and disassembly, wash parts well to remove dust and dirt before lubrication. If lubrication is removed when cleaning, or if parts have been disassembled or replaced, always re-lubricate them. Run the sliding parts after lubricating to allow the lubrication to be evenly distributed.

2-3.Lubricated Areas

Refer to Fig. 2-4.

No.	Lubricating Point	Grease/Oil
①	Rubbing surfaces of Lock shaft and Platen holder	EM-30L
②	Rubbing surfaces of Lock shaft and Base Frame Unit	EM-30L
③	Rubbing surfaces of Gear shaft and Gear 36 x 56 x 0.5	EM-30L
④	Rubbing surfaces of Gear shaft and Gear 18 x 0.7 - 58 x0.5	EM-30L
⑤	Cut surfaces of Paper guide	Mobil 1

Notes : Use a brush or cotton swab to lubricate the cut surface (⑤) of the paper guide. Make sure it does not soil paper that passes through.

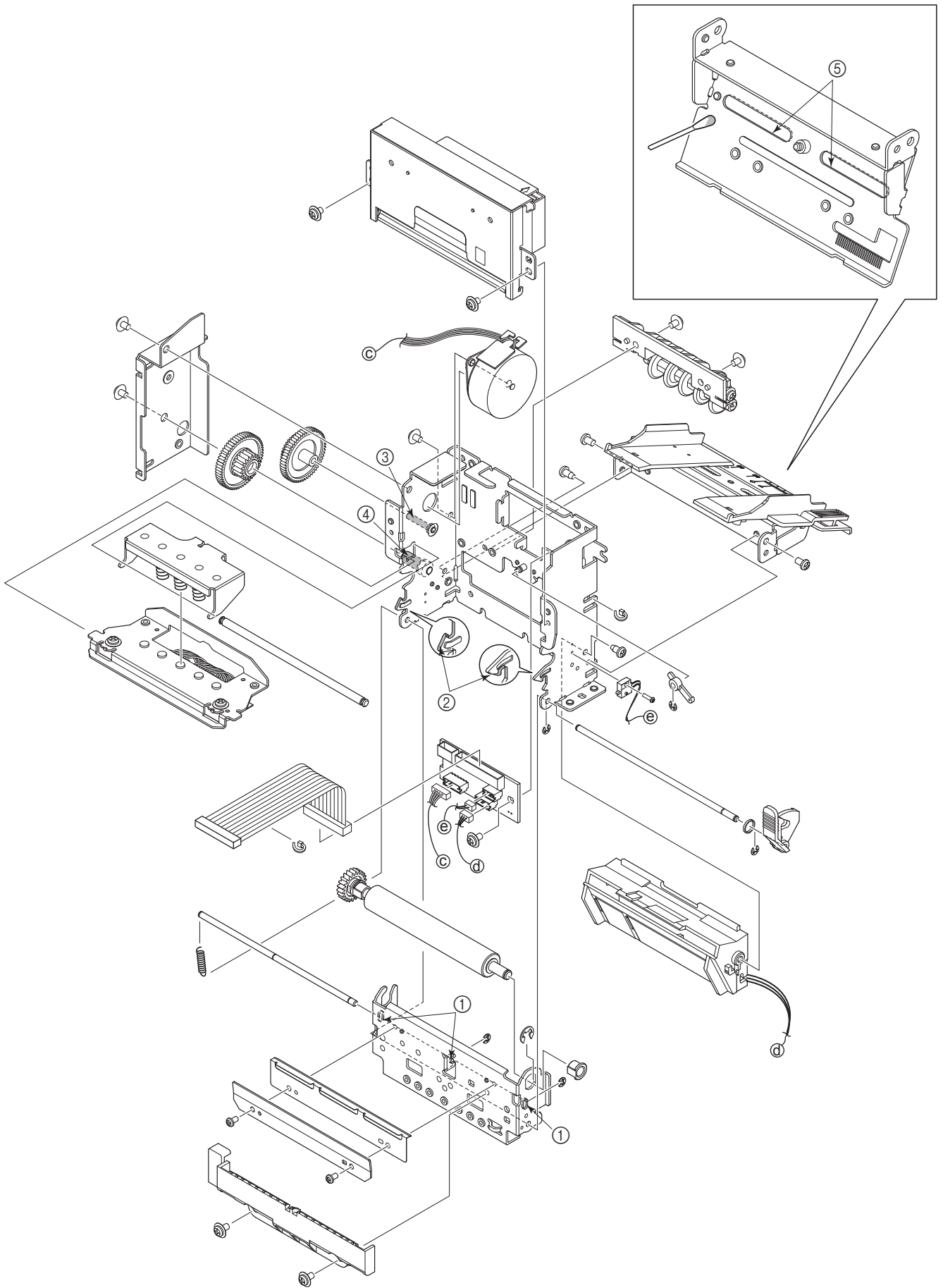

Fig. 2-4 Lubricated Areas (TMP542)

CHAPTER 3

PARTS LIST

HOW TO USE PARTS LIST

- (1) DRWG. NO.
This column shows the drawing number of the illustration.
- (2) REVISED EDITION MARK
This column shows a revision number.
Part that have been added in the revised edition are indicated with “#”.
Part that have been abolished in the revised edition are indicated with “*”.
#1 : First edition → Second edition *1 : First edition → Second edition
- (3) PART NO.
Parts numbers must be notified when ordering replacement parts. Parts described as “NPN” have no parts number and are not in stock, i.e., unavailable.
- (4) PARTS NAME
Parts names must be notified when ordering replacement parts.
- (5) Q'TY
This column shows the number of the part used as indicated in the figure.
- (6) REMARKS
When differences in specifications exist depending on location/destination.
- (7) RANK
Parts marked “S” in the rank column can be ordered. Other parts, as a rule, cannot be supplied even if ordered.
Parts marked “O” are optional parts.

<p>1. Printer Assembly 13</p> <p> 1-1. Disassembly Drawing13</p> <p> 1-2. Parts List.....15</p> <p>2. Mechanism Base Unit 16</p> <p> 2-1. Disassembly Drawing16</p> <p> 2-2. Parts List.....18</p> <p>3. Printer Mechanism Unit 19</p> <p> 3-1. Disassembly Drawing19</p> <p> 3-2. Parts List.....21</p> <p>4. Sub-Assembly.....23</p> <p> 4-1. Frame R Unit.....23</p> <p> 4-2. Frame L Unit24</p> <p> 4-3. Board chassis L Unit25</p> <p> 4-4. Presenter Unit PR521.....26</p> <p> 4-5. Paper Guide Unit (PR521).....28</p> <p> 4-6. Guide Frame Unit29</p> <p> 4-7. Head Unit30</p> <p> 4-8. Platen Holder Unit.....31</p> <p> 4-9. Paper Guide Unit.....32</p> <p>5. Block Diagram 33</p> <p>6. Main Logic Board 34</p> <p> 6-1. Circuit Diagram34</p> <p> 6-2. Component Layout39</p> <p> 6-3. Circuit Number Diagram.....40</p> <p> 6-4. Parts List.....41</p> <p>7. Sub Board 46</p> <p> 7-1. Circuit Diagram46</p> <p> 7-2. Component Layout46</p> <p> 7-3. Parts List.....46</p>	<p>8. Operation Panel Board.....47</p> <p> 8-1. Circuit Diagram47</p> <p> 8-2. Component Layout47</p> <p> 8-3. Parts List.....47</p> <p>9. Snout Board 48</p> <p> 9-1. Circuit Diagram48</p> <p> 9-2. Component Layout48</p> <p> 9-3. Parts List.....48</p> <p>10. Serial Interface Board(25pin)..... 49</p> <p> 10-1. Circuit Diagram49</p> <p> 10-2. Parts List.....50</p> <p>11. Serial Interface Board(9pin)..... 51</p> <p> 11-1. Circuit Diagram51</p> <p> 11-2. Parts List.....52</p> <p>12. Parallel Interface Board 53</p> <p> 12-1. Circuit Diagram53</p> <p> 12-2. Parts List.....54</p> <p>13. USB Interface Board..... 55</p> <p> 13-1. Circuit Diagram55</p> <p> 13-2. Component Layout56</p> <p> 13-3. Parts List.....57</p> <p>14. Ethernet Interface Board..... 58</p> <p> 14-1. Circuit Diagram58</p> <p> 14-2. Component Layout63</p> <p> 14-3. Parts List.....64</p>
--	---

1. Printer Assembly

1-1. Disassembly Drawing

A. TUP592

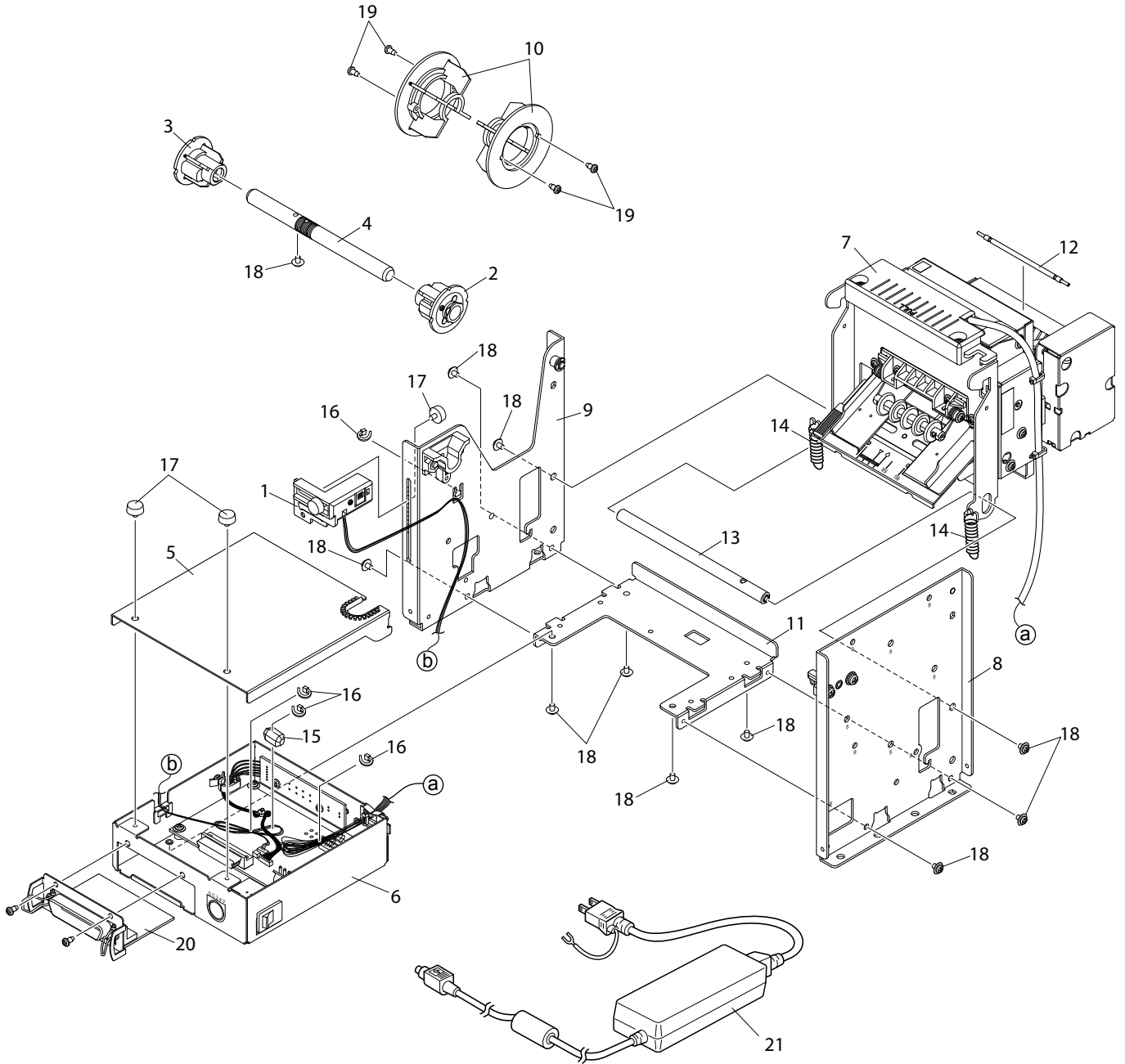

B. TUP542

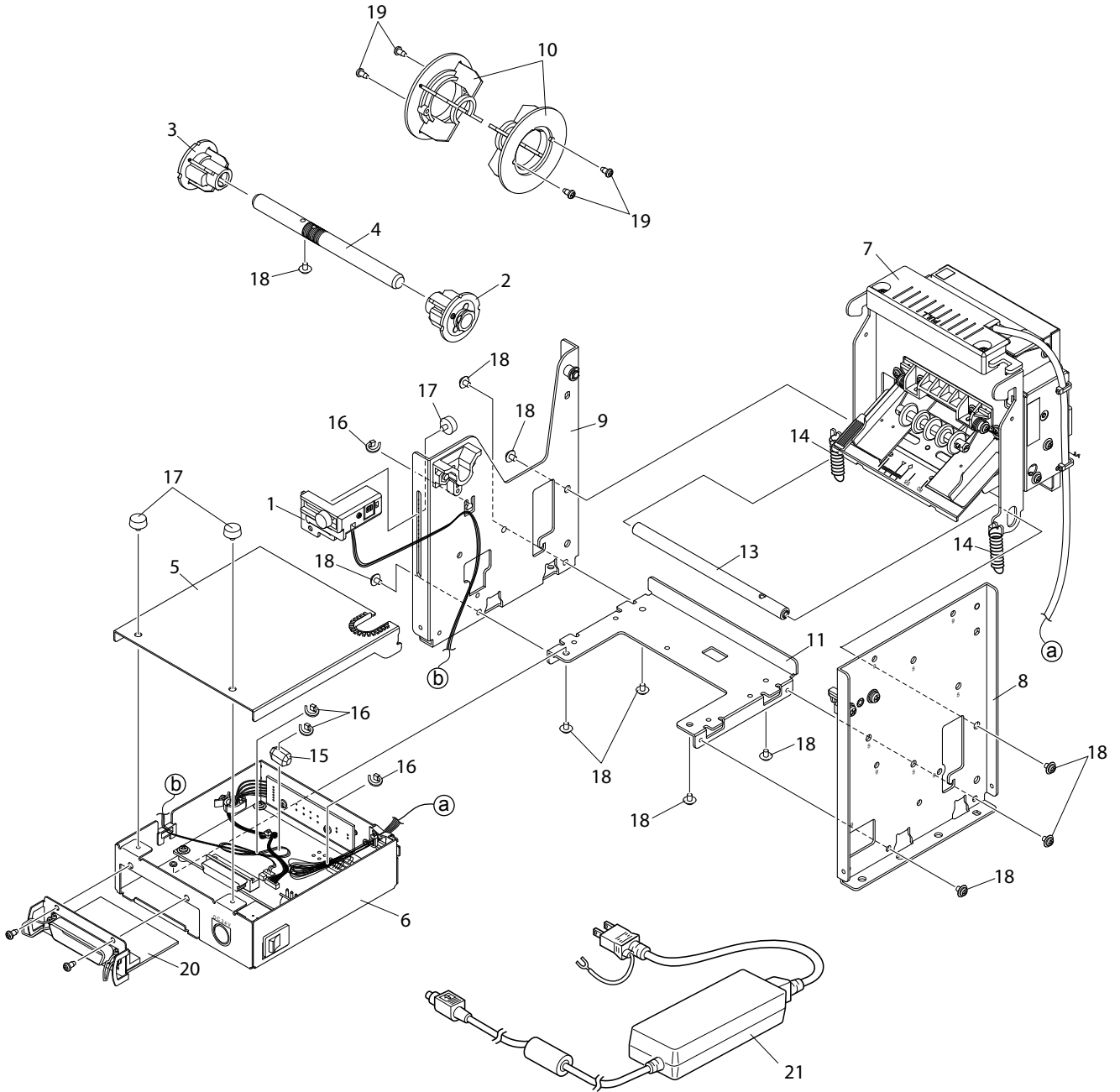

1-2. Parts List

Printer Assembly

DRWG.NO.	REV.	PARTS NO.	PARTS NAME	Q' TY	REMARKS	RANK
1		39590310	NEU-T500	1		O
2		37421600	ROLL PAPER HOLDER S ASSY TUP5	1		S
3		33914240	ROLL PAPER HOLDER S TUP5	1		S
4		NPN	ROLL PAPER SHAFT TUP5	1		
5		NPN	BOARD CHASSIS U UNIT TUP5	1		
6		NPN	BOARD CHASSIS L UNIT TUP5	1		
7		37420420	MECHANISM BASE UNIT TUP5	1	TUP592	S
		37420430	MECHANISM BASE A UNIT TUP5	1	TUP542	S
8		NPN	FRAME L UNIT TUP5	1		
9		NPN	FRAME R UNIT TUP5	1		
10		33914250	ROLL PAPER HOLDER M TUP5	2		S
11		NPN	BOTTOM FRAME TUP5	1		
12		NPN	WEIGHT BAR PR5	1	TUP592	
13		NPN	FRAME STAY TUP5	1		
14		30510900	SPRING E093-090-0284	2		S
15		NPN	FERRITE CORE SFC-3	1		
16		04991204	FASTENER T18S	4		S
17		01923004	DESIGNED SCREW 3-4	3		S
18		01903030	SCREW TR 3-4 FL	1		S
19		00930603	SCREW TAT 3-6 PT	4		S
20		39607510	INTERFACE BOARD IFBD-HU05	1	OPTION:USB	O
		39607502	INTERFACE BOARD IFBD-HE05	1	OPTION:ETHERNET	O
		39607300	INTERFACE BOARD IFBD-HN03	1	OPTION:SERIAL 9 PIN	O
		39607211	INTERFACE BOARD IFBD-HC03	1	OPTION:PARALLEL IF	O
		39607200	INTERFACE BOARD IFBD-HD03	1	OPTION:SERIAL 25 PIN	O
21		30781790	ADAPTER SET PS60A-24B CH	1	OPTION	O
		30781780	ADAPTER SET PS60A-24B AS	1	OPTION	O
		30781770	ADAPTER SET PS60A-24B UK	1	OPTION	O
		30781760	ADAPTER SET PS60A-24B EU	1	OPTION	O
		30781750	ADAPTER SET PS60A-24B US	1	OPTION	O
-		39590300	RHU-T500	1	OPTION	O
		39591010	DRU-T500B	1	OPTION	O

2. Mechanism Base Unit

2-1. Disassembly Drawing

A. TUP592

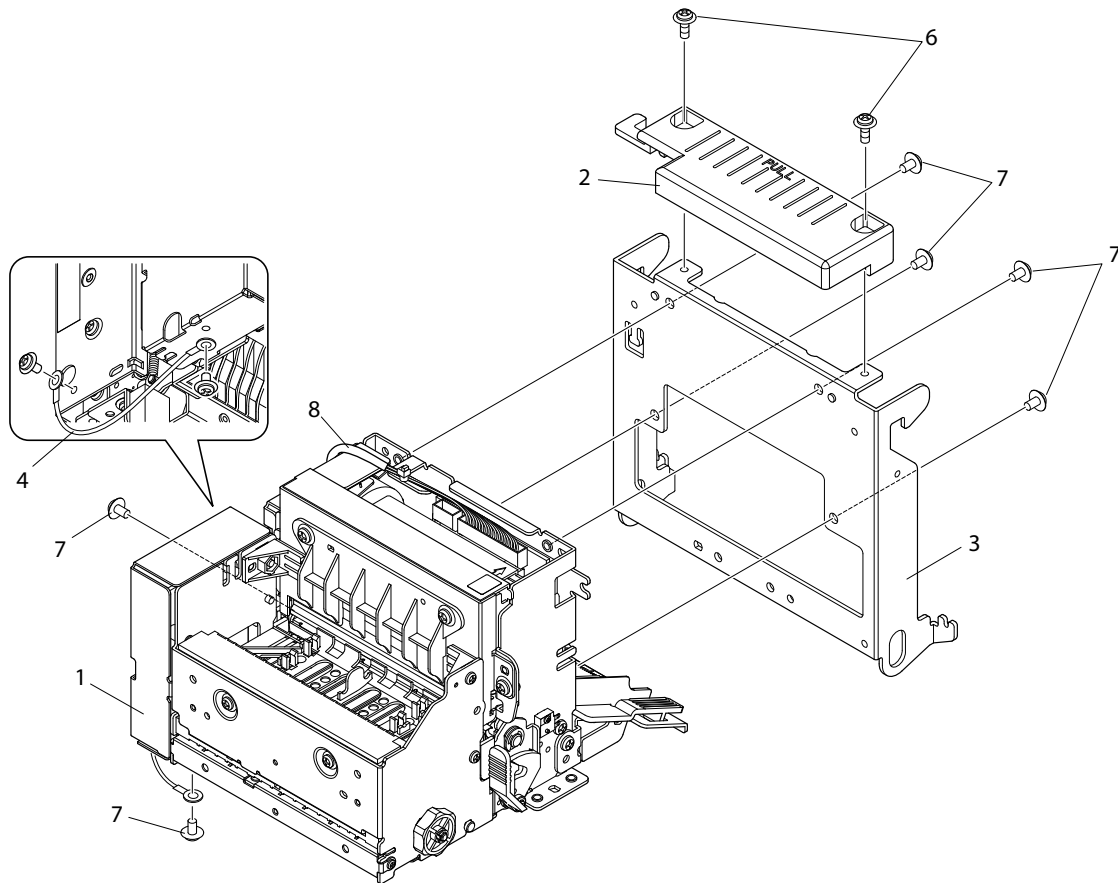

B.TUP542

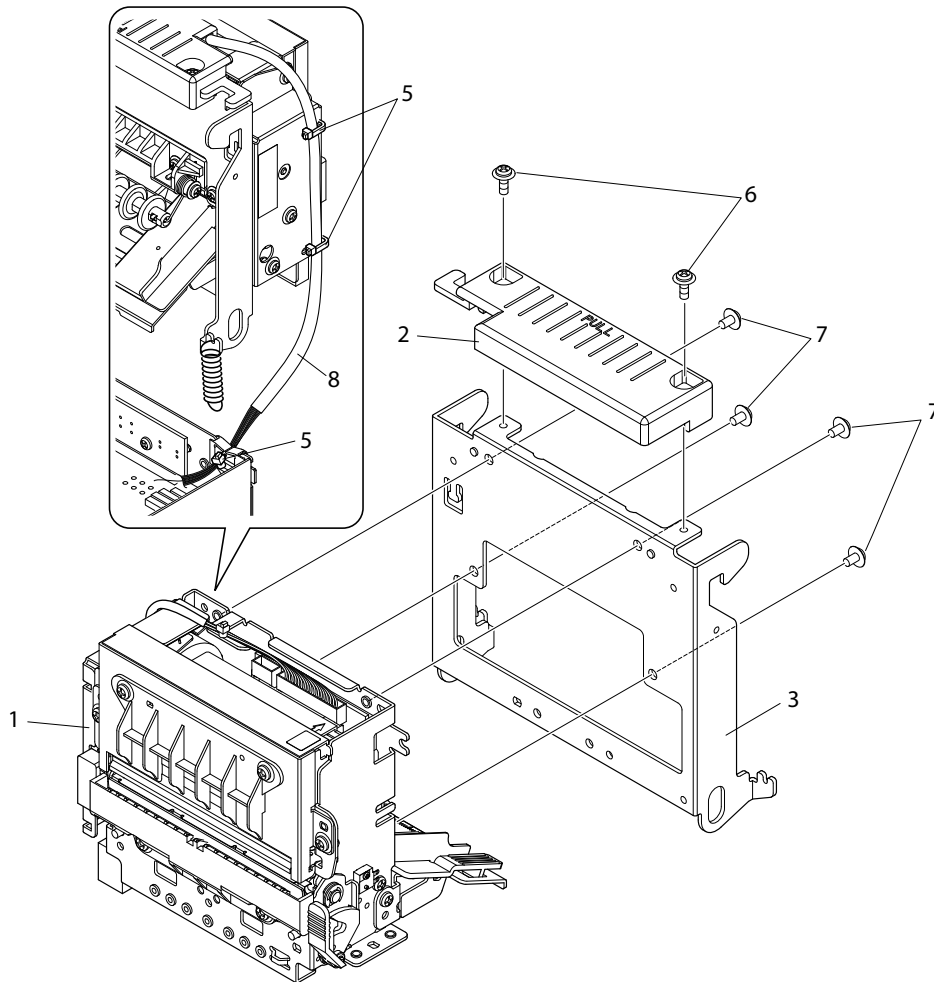

2-2. Parts List

Mechanism Base Unit

DRWG.NO.	REV.	PARTS NO.	PARTS NAME	Q' TY	REMARKS	RANK
1		38400000	TMP592-24	1	TUP592	S
		39454000	TMP542-24-A	1	TUP542	O
2		33913000	HANDLE TUP9	1		S
3		NPN	MECHANISM BASE TUP5	1		
4		NPN	WIRE 18UL1007BRN060TT	1	TUP592	
5		04991204	FASTENER T18S	3	TUP542	S
6		01903090	SCREW TAT 3-8 CT-FL	2		S
7		01903077	SCREW TAT 3-5 CT-FL	6	TUP592	S
		01903077	SCREW TAT 3-5 CT-FL	4	TUP542	S
8		09992102	SPIRAL TUBE 6.0	1		S

3. Printer Mechanism Unit

3-1. Disassembly Drawing

A. TUP592

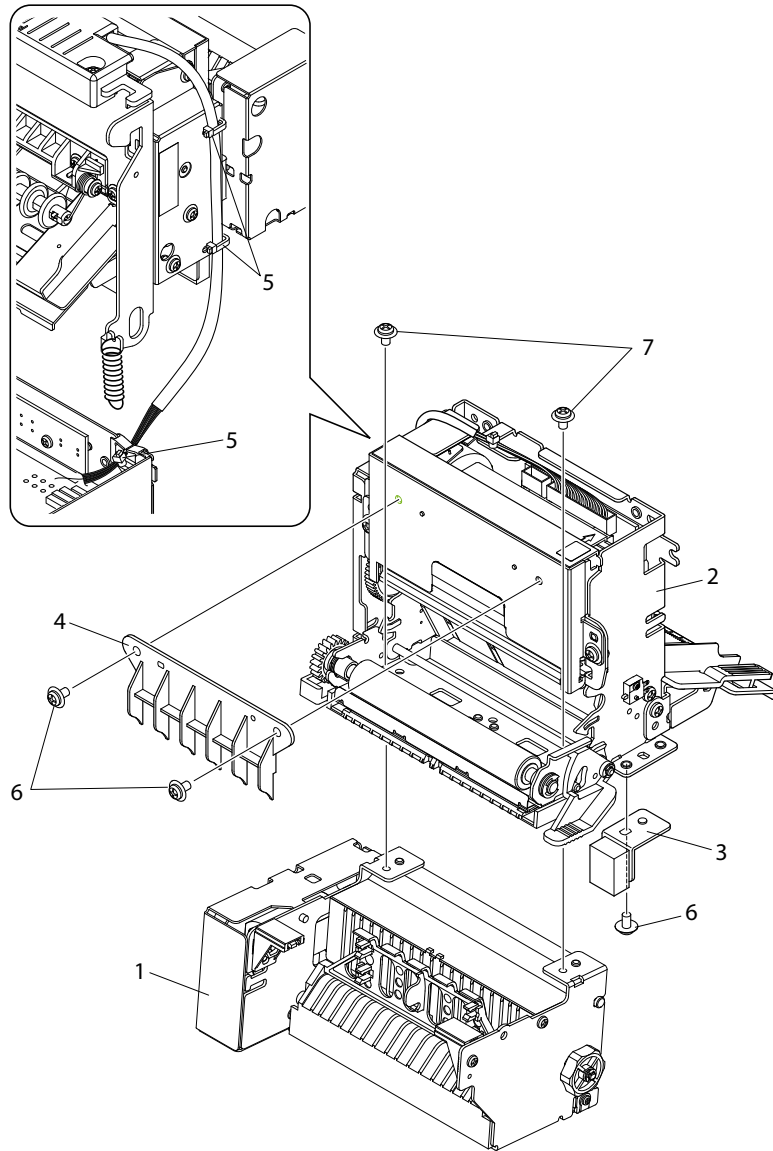

B. TUP542

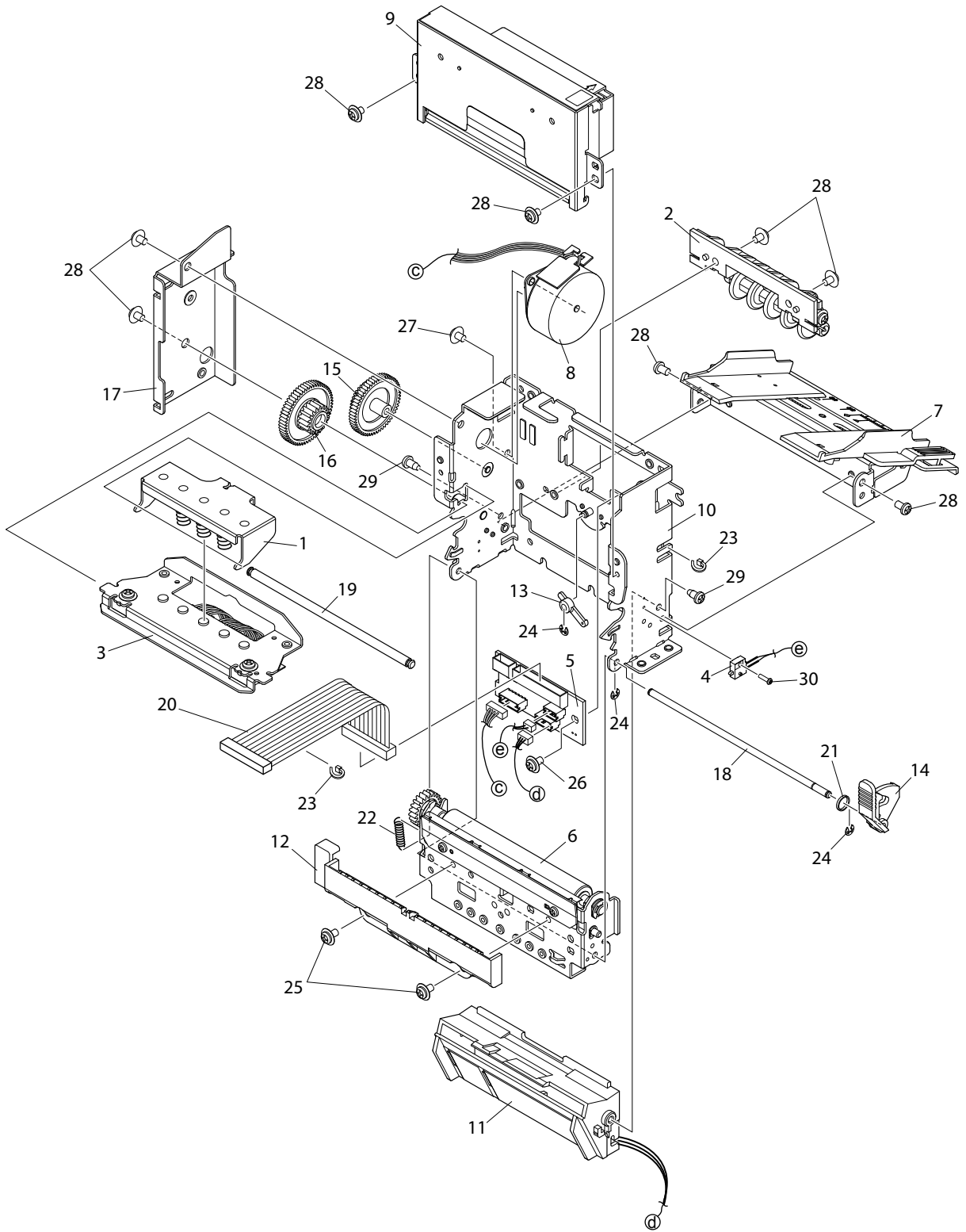

3-2. Parts List

Printer Mechanism Unit (TUP592)

DRWG.NO.	REV.	PARTS NO.	PARTS NAME	Q' TY	REMARKS	RANK
1		39515200	PR521-24-A	1		O
2		39454000	TMP542-24-A	1		O
3		37413800	STOPPER UNIT TMP5	1		S
4		33914310	LOOP GUIDE PR5	1		S
5		04991204	FASTENER T18S	3		S
6		01903077	SCREW TAT 3-5 CT-FL	3		S
7		01903030	SCREW TR 3-4 FL	2		S

Printer Mechanism Unit (TUP542)

DRWG.NO.	REV.	PARTS NO.	PARTS NAME	Q' TY	REMARKS	RANK
1		37483030	SPRING HOLDER UNIT TMP9	1		S
2		37425500	DAMPER ROLLER AASSY TUP5	1		S
3		37419020	HEAD UNIT TMP5	1		S
4		37417200	PLATEN SWITCH UNIT TMP5	1		S
5		37417100	TERMINAL BOARD UNIT TMP5	1		S
6		37413200	PLATEN HOLDER UNIT TMP5	1		S
7		37413010	PAPER GUIDE UNIT TMP5	1		S
8		37412100	PF MOTOR UNIT TMP5	1		S
9		37412010	CUTTER UNIT TMP5	1		S
10		NPN	BASE FRAME UNIT TMP5	1		
11		33914230	PAPER FEEDER TMP5	1		S
12		33914200	BLADE COVER TMP5	1		S
13		33490060	HEAD ADJUSTER TMP9	1		S
14		33400121	RELEASE LEVER TMP9	1		S
15		33102300	GEAR 36X56X0.5 TMP9	1		S
16		33102290	GEAR 18X0.7-58X0.5 TMP9	1		S
17		NPN	GEAR COVER TMP5	1		
18		NPN	PLATEN PIVOT TMP5	1		
19		NPN	PRESS SHAFT TMP5	1		
20		30721701	CABLE UNIT 14X380CC TMP9	1		S
21		30531160	RELEASE SPRING TMP9	1		S
22		30510350	SPRING E038-040-0118	1		S
23		04991204	FASTENER T18S	2		S
24		04020010	STOP RING SE2.0	3		S
25		01902123	SCREW TAT 3-6 CT-FL-ZN	2		S
26		01903077	SCREW TAT 3-5 CT-FL	1		S
27		01903064	SCREW TAT 3-5 CT	2		S
28		01903030	SCREW TR 3-4 FL	7		S
29		00930603	SCREW TAT 3-6 PT	2		S
30		00816604	SCREW TR 1.6-6	1		S

4. Sub-Assembly

4-1. Frame R Unit

9-

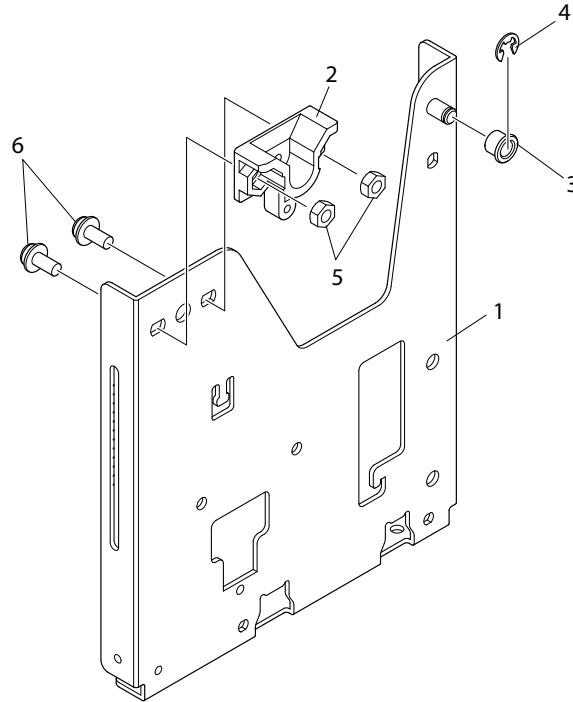

DRWG.NO.	REV.	PARTS NO.	PARTS NAME	Q' TY	REMARKS	RANK
9-1		NPN	FRAME R ASSY TUP9	1		
9-2		33210520	BUSHING TUP9	1		S
9-3		30211050	PF ROLLER BEARING TMP6	1		S
9-4		04020016	STOP RING SE4.0	1		S
9-5		02010401	HEXAGON NUT NH4-1	2		S
9-6		01914003	SCREW TR 4-10 WS/WF	2		S

4-2. Frame L Unit

8-

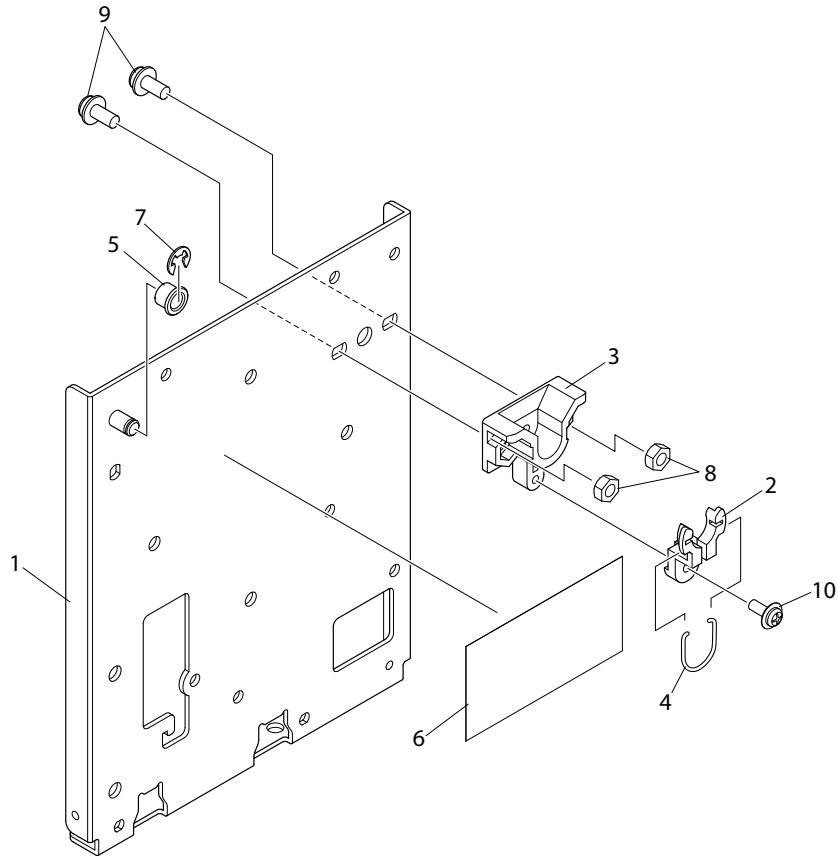

DRWG.NO.	REV.	PARTS NO.	PARTS NAME	Q' TY	REMARKS	RANK
8-1		NPN	FRAME L ASSY TUP9	1		
8-2		33912000	CLAMP TUP9	1		S
8-3		33210520	BUSHING TUP9	1		S
8-4		30531180	CLAMP SPRING TUP9	1		S
8-5		30211050	PF ROLLER BEARING TMP6	1		S
8-6		NPN	PAPER SET SEAL TUP9	1		
8-7		04020016	STOP RING SE4.0	1		S
8-8		02010401	HEXAGON NUT NH4-1	2		S
8-9		01914003	SCREW TR 4-10 WS/WF	2		S
8-10		01903060	SCREW TAT 3-8 PT-FL	1		S

4-3. Board chassis L Unit

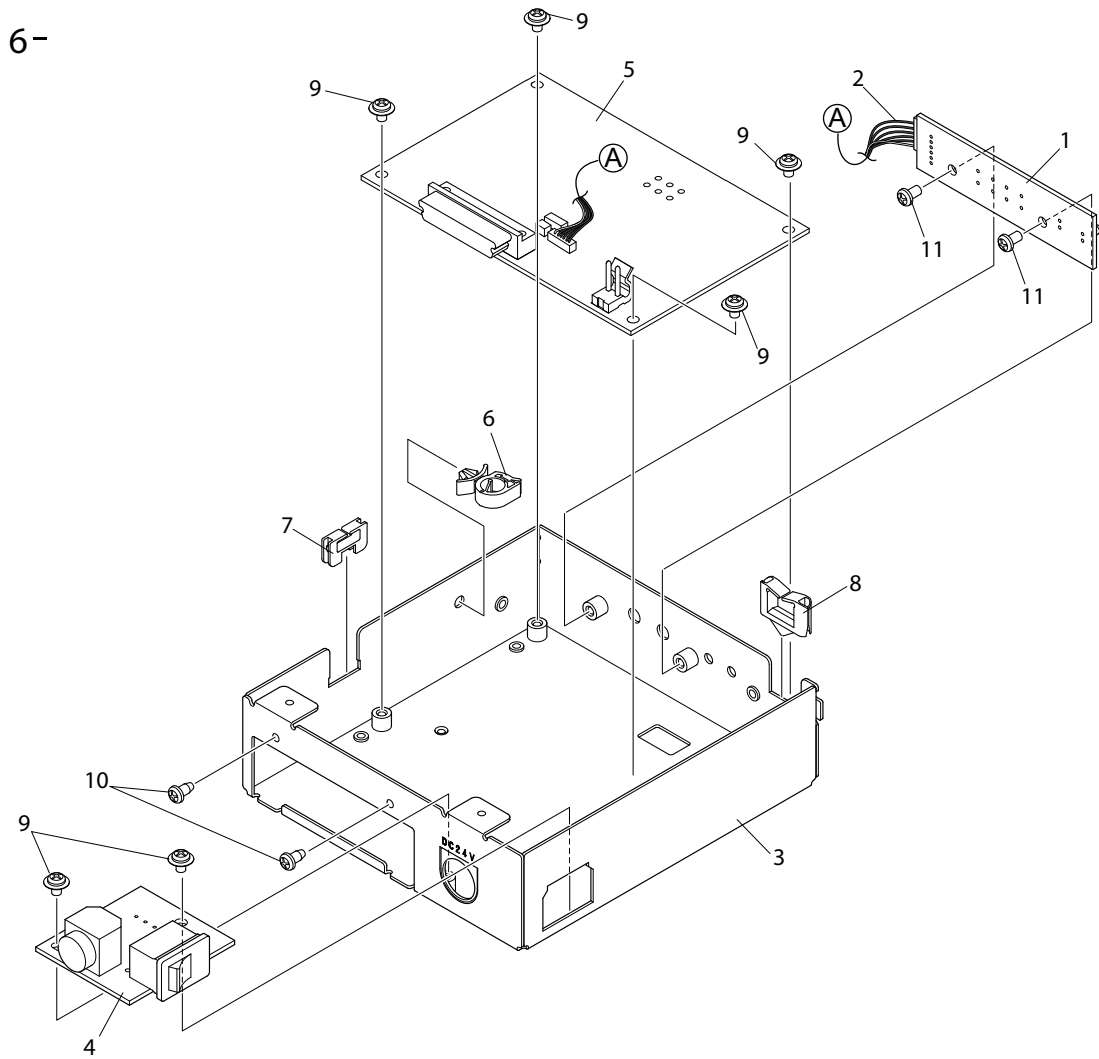

DRWG.NO.	REV.	PARTS NO.	PARTS NAME	Q' TY	REMARKS	RANK
6-1		39591500	OPA-T900	1		O
6-2		37427910	CABLE UNIT 6X220CC ASSY TUP5	1		S
6-3		NPN	BOARD CHASSIS L ASSY TUP5	1		
6-4		39206600	POWER SUB BOARD PBD-5	1		O
6-5		39206100	CONTROL BOARD TBD500-24-A	1		O
6-6		04991902	MINI CORD CLAMP ES-6U	1		S
6-7		04991258	CORD CLAMP ES-0510	1		S
6-8		04991254	CORD CLAMP EDS-1208U	1		S
6-9		01903030	SCREW TR 3-4 FL	6		S
6-10		00930609	SCREW TAT 3-6 CT	2		S
6-11		00630504	SCREW TR 3-5	2		S

4-4. Presenter Unit PR521

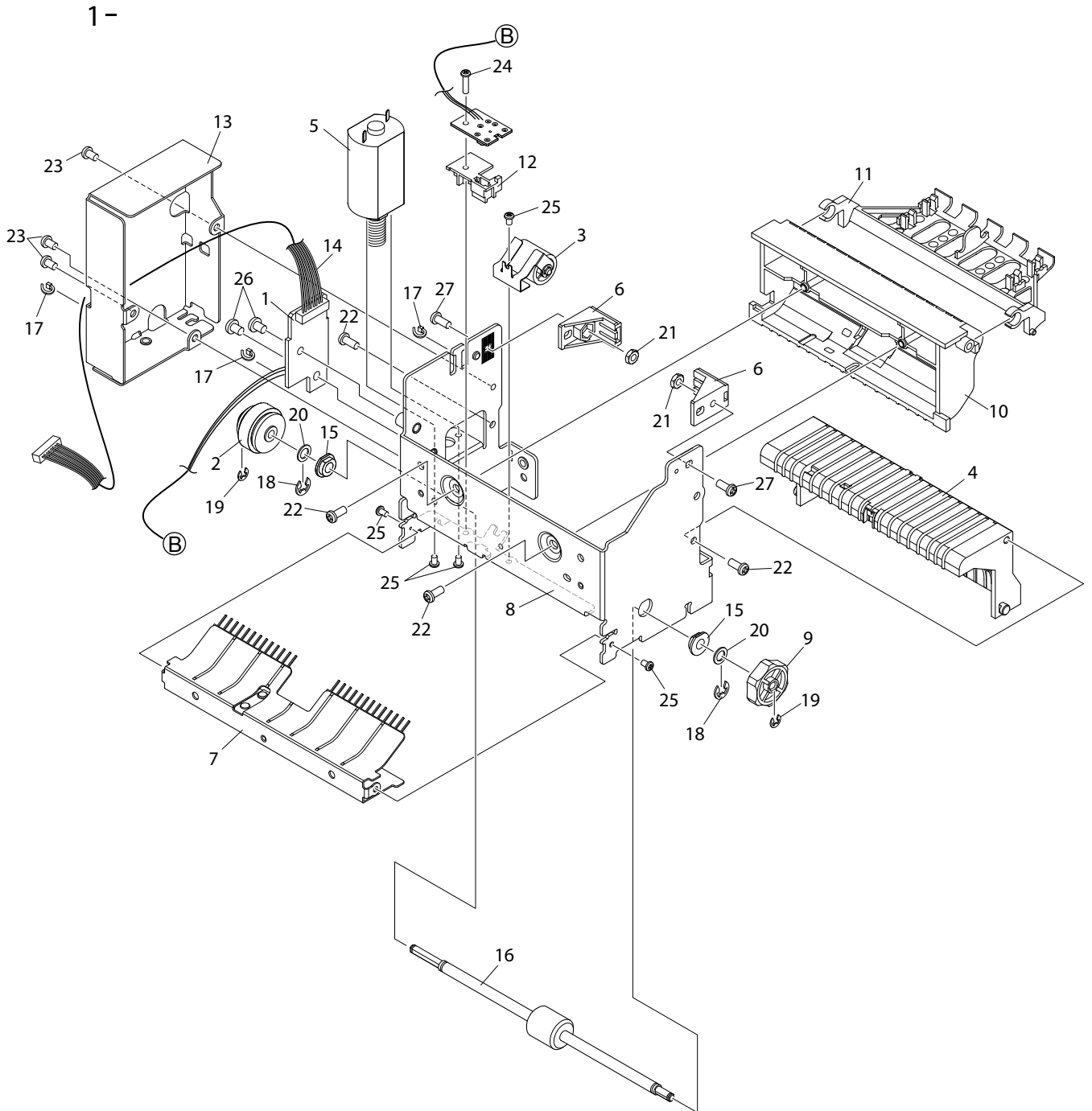

DRWG.NO.	REV.	PARTS NO.	PARTS NAME	Q' TY	REMARKS	RANK
1-1		37517060	TERMINAL BOARD UNIT PR5	1		S
1-2		37514030	SLIP WHEEL UNIT PR5	1		S
1-3		37513100	ROLLER HOLDER UNIT PR5	1		S
1-4		37513080	PAPER GUIDE UNIT PR5	1		S
1-5		37512030	PAPER FEED MOTOR UNIT PR9	1		S
1-6		37511100	MAGNET COVER UNIT PR5	2		S
1-7		NPN	GUIDE FRAME UNIT PR5	1		
1-8		NPN	PRESENTER FRAME UNIT PR5	1		
1-9		33990010	KNOB PR9	1		S
1-10		33914290	REAR GUIDE PR5	1		S
1-11		33914280	PAPER HOLDER PR5	1		S
1-12		33911160	DETECTOR HOLDER PR5	1		S
1-13		NPN	GEAR COVER PR5	1		
1-14		30721740	CABLE UNIT 8X350CC PR9	1		S
1-15		30211080	PF ROLLER BEARING MP5III	2		S
1-16		30201210	PAPER FEED ROLLER PR5	1		S
1-17		04991204	FASTENER T18S	3		S
1-18		04020015	STOP RING SE3.0	2		S
1-19		04020010	STOP RING SE2.0	2		S
1-20		02304050	POLY-SLIDER WP4X0.5	2		S
1-21		02030261	HEXAGON NUT NH2.6-3	2		S
1-22		01902615	SCREW TAT 2.6-6 PT	4		S
1-23		00926403	SCREW TAT 2.6-4 CT	3		S
1-24		00820804	SCREW TR 2-8	1		S
1-25		00820304	SCREW TR 2-3	5		S
1-26		00630404	SCREW TR 3-4	2		S
1-27		00626604	SCREW TR 2.6-6	2		S

4-5. Paper Guide Unit (PR521)

1-4-

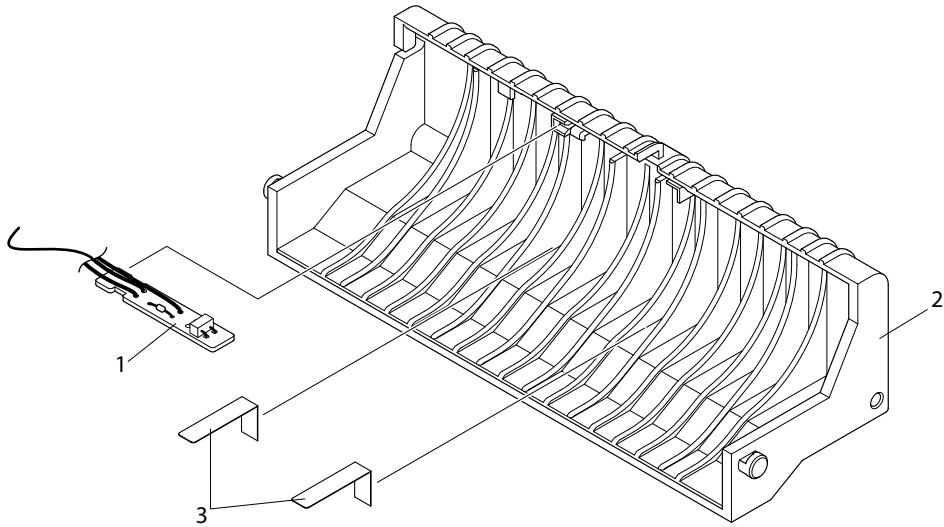

DRWG.NO.	REV.	PARTS NO.	PARTS NAME	Q' TY	REMARKS	RANK
1-4-1		37517210	PE DETECTOR ASSY A PR5	1		S
1-4-2		NPN	PAPER GUIDE PR5	1		
1-4-3		30045110	GUIDE PR5	2		S

4-6. Guide Frame Unit

1-7-

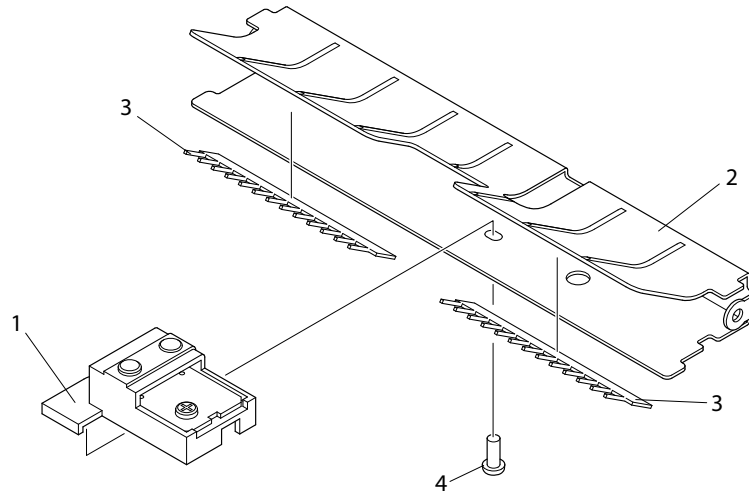

DRWG.NO.	REV.	PARTS NO.	PARTS NAME	Q' TY	REMARKS	RANK
1-7-1		37511500	DETECTOR COVER ASSY PR5	1		S
1-7-2		NPN	GUIDE FRAME PR5	1		
1-7-3		30992050	DISCHARGE BRUSH PR5	2		S
1-7-4		01902028	SCREW TAT 2-4	1		S

4-7. Head Unit

2-3-

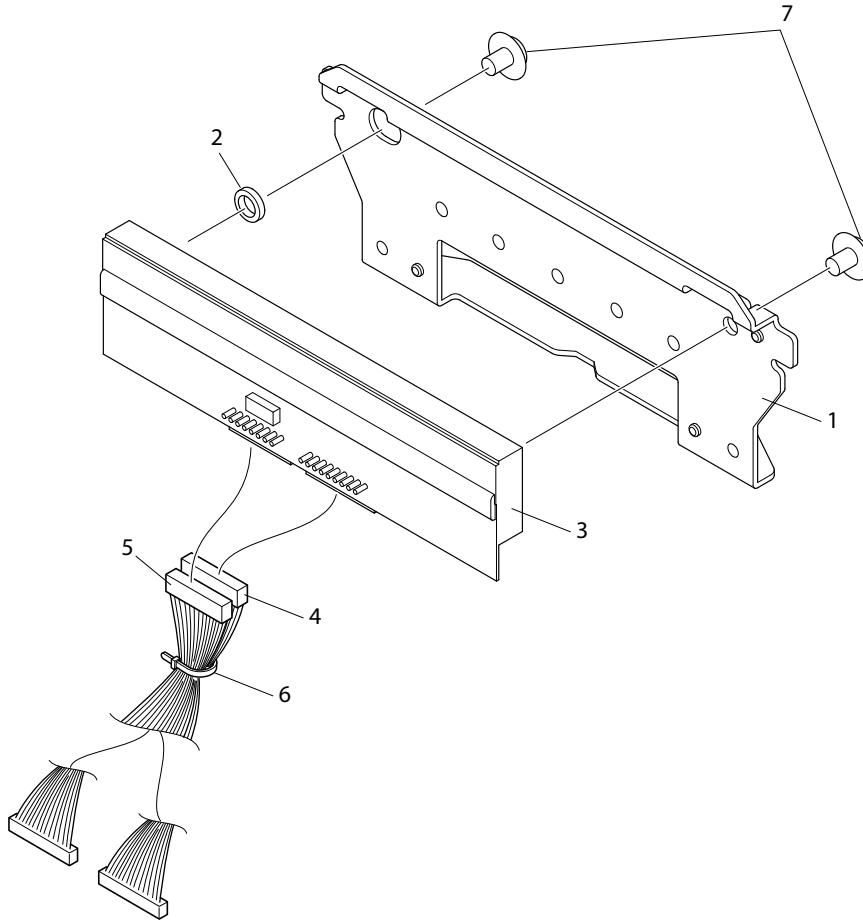

DRWG.NO.	REV.	PARTS NO.	PARTS NAME	Q' TY	REMARKS	RANK
2-3-1		NPN	HEAD HOLDER TMP5	1		
2-3-2		31210001	COLLAR TMP8	1		S
2-3-3		30905090	THERMAL HEAD TAE080-H8E621	1		S
2-3-4		30723190	CABLE UNIT B TMP5	1		S
2-3-5		30723180	CABLE UNIT A TMP5	1		S
2-3-6		04991204	FASTENER T18S	1		S
2-3-7		01903030	SCREW TR 3-4 FL	2		S

4-8. Platen Holder Unit

2-6-

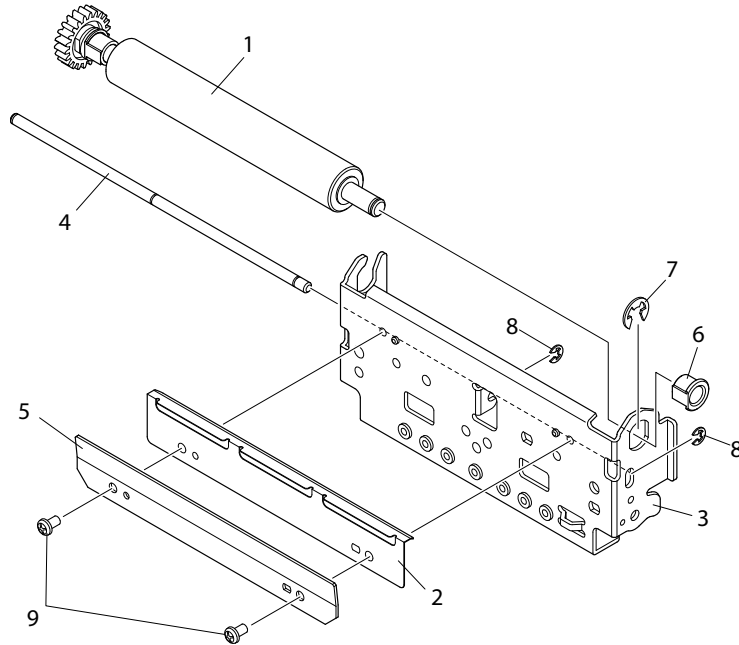

DRWG.NO.	REV.	PARTS NO.	PARTS NAME	Q' TY	REMARKS	RANK
2-6-1		37413700	PLATEN ASSY TMP5	1		S
2-6-2		NPN	BLADE GUIDE TMP10	1		
2-6-3		NPN	PLATEN HOLDER TMP5	1		
2-6-4		NPN	LOCK SHAFT TMP5	1		
2-6-5		30903100	STATIONARY KNIFE KC-GS90	1		S
2-6-6		30211090	PF ROLLER BEARING TMP5	2		S
2-6-7		04020016	STOP RING SE4.0	1		S
2-6-8		04020010	STOP RING SE2.0	2		S
2-6-9		00926403	SCREW TAT 2.6-4 CT	2		S

4-9. Paper Guide Unit

2-7-

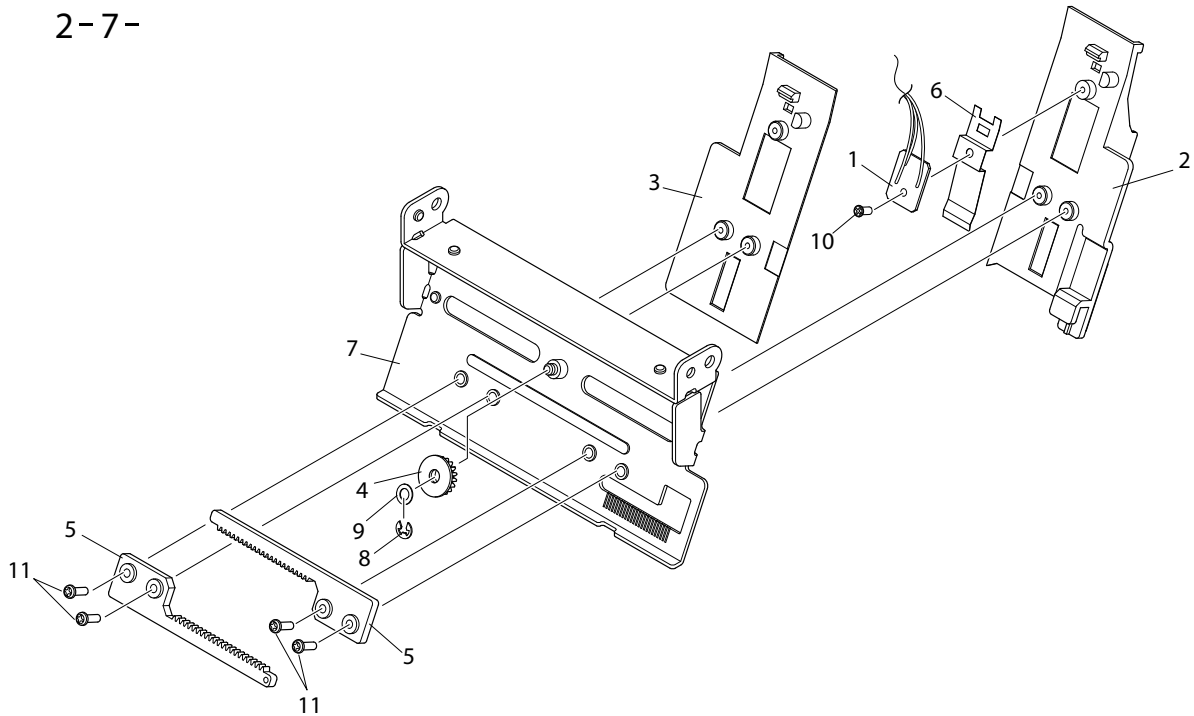

DRWG.NO.	REV.	PARTS NO.	PARTS NAME	Q' TY	REMARKS	RANK
2-7-1		37417500	PE DETECTOR ASSY TMP5	1		S
2-7-2		33914220	SIDE GUIDE R TMP5	1		S
2-7-3		33914210	SIDE GUIDE L TMP5	1		S
2-7-4		33100240	GUIDE PINION 18X0.5 TMP9	1		S
2-7-5		33090040	RACK TMP5	2		S
2-7-6		32592140	GROUND SPRING TMP5	1		S
2-7-7		NPN	PAPER GUIDE ASSY TMP5	1		
2-7-8		04020010	STOP RING SE2.0	1		S
2-7-9		02303025	POLY-SLIDER WP3X0.25	1		S
2-7-10		01902028	SCREW TAT 2-4	1		S
2-7-11		00920603	SCREW TAT 2-6 PT	4		S

5. Block Diagram

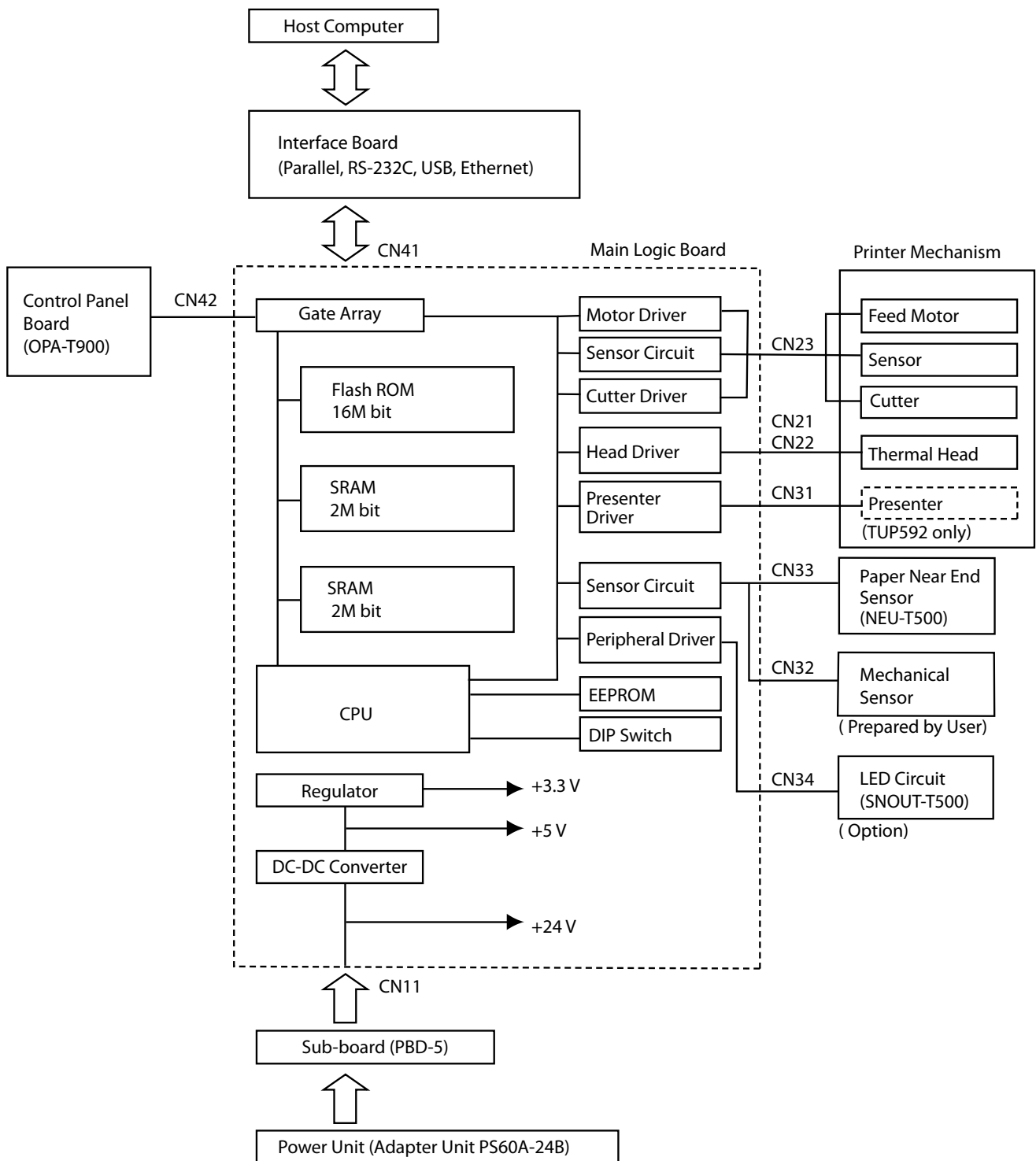

6. Main Logic Board

6-1. Circuit Diagram

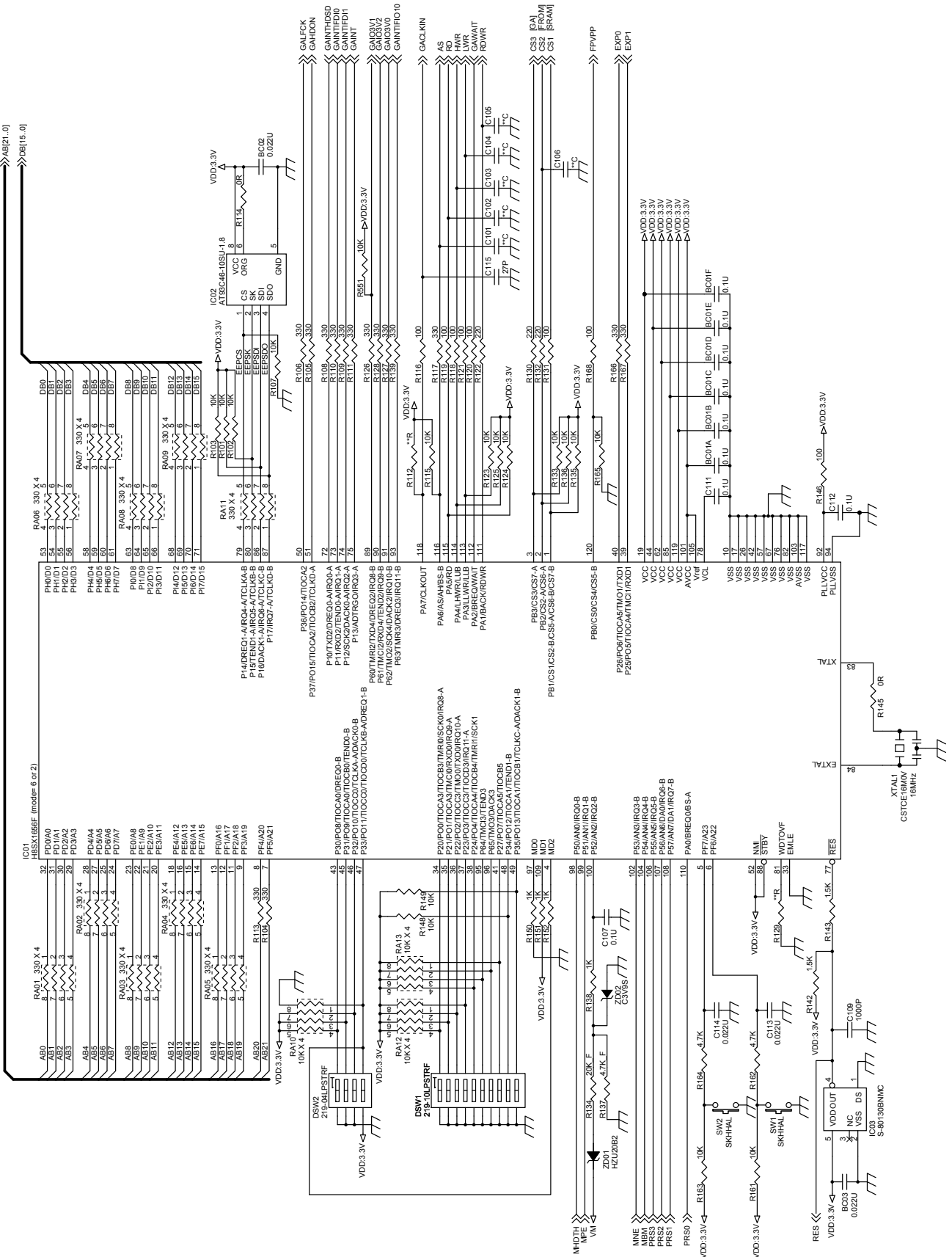

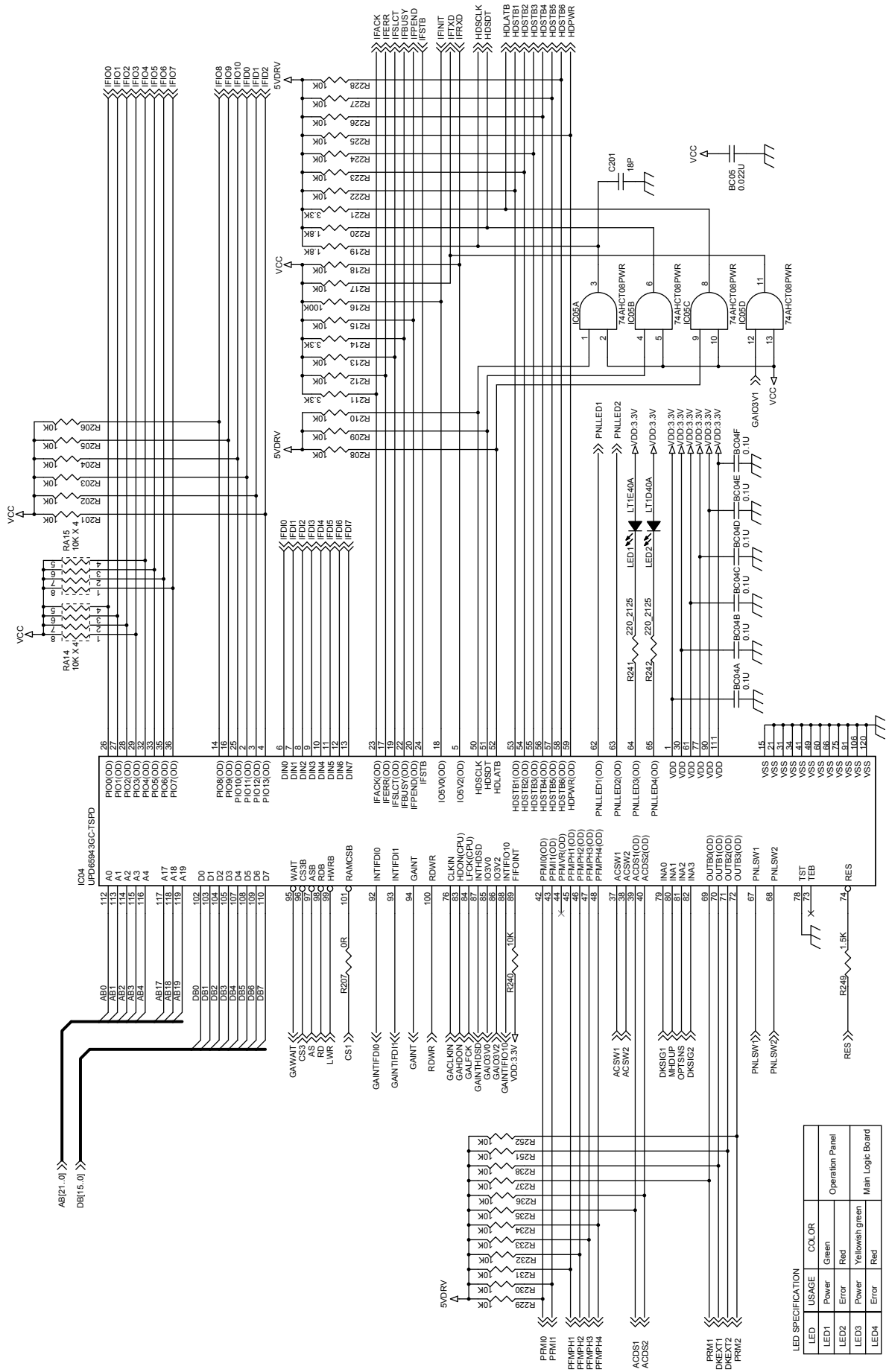

LED	USAGE	COLOR
LED1	Power	Green
LED2	Error	Red
LED3	Power	Yellowish green
LED4	Error	Red

Operation Panel
Main Logic Board

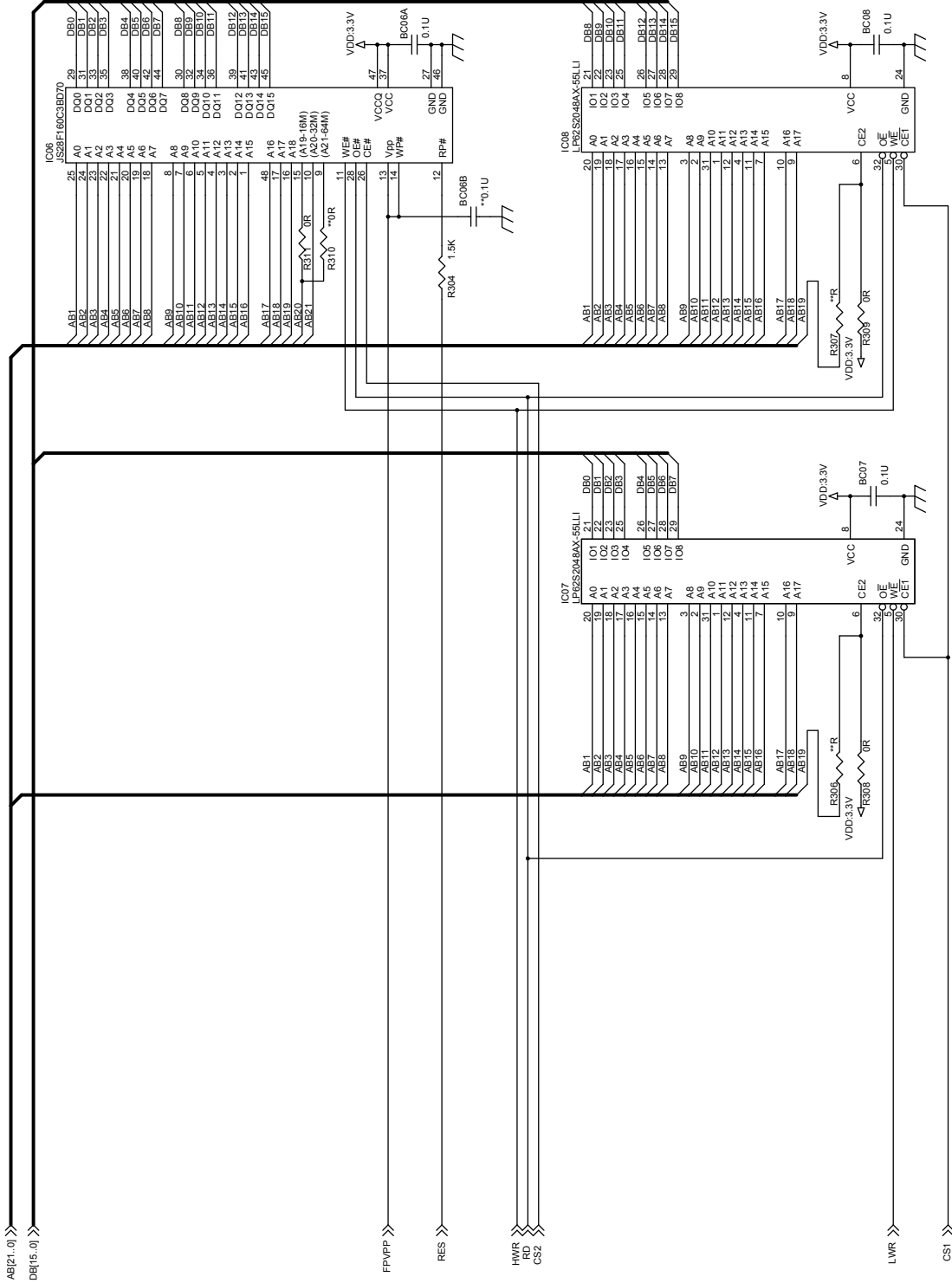

< Support of SRAM Memory UP:
 IC07+IC08 2Mbit+2Mbit/4Mbit+4Mbit+4Mbit(width of bus x 16bit) >

Parts No.	Memory	R306	R307	R308	R309
IC07+IC08	2M+2M	**	**	0R	0R
	4M+4M	0R	0R	**	**

< Support of manufactured by SHARP FROM (Usually Intel) >

Parts No.	Manufacturer/Model No.	R310	R311
IC06	Intel/JS28F160C3BD70	**	0R
	SHARP/LH28F160BJHE-PBTL70	0R	**

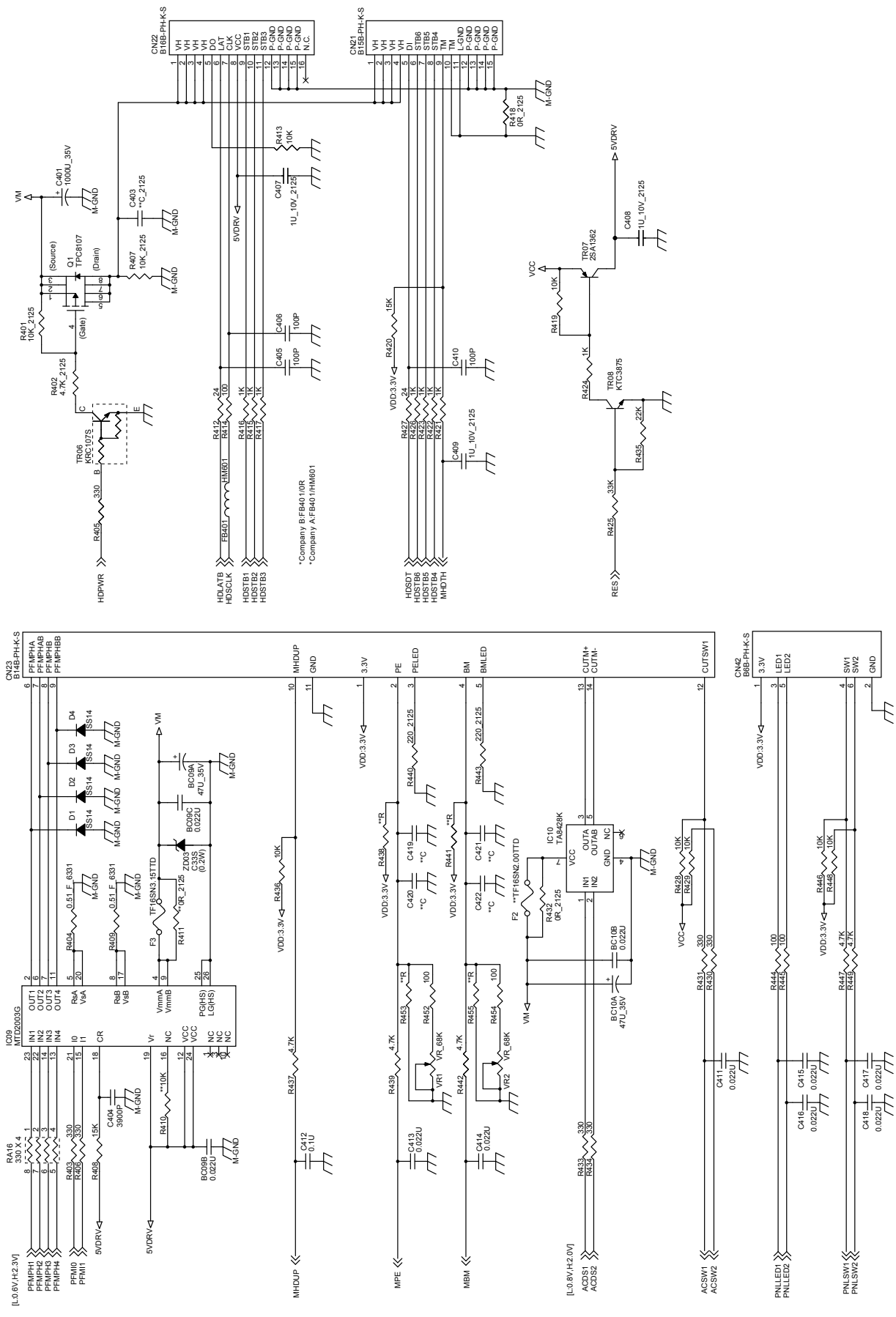

Main Logic Board 4/5

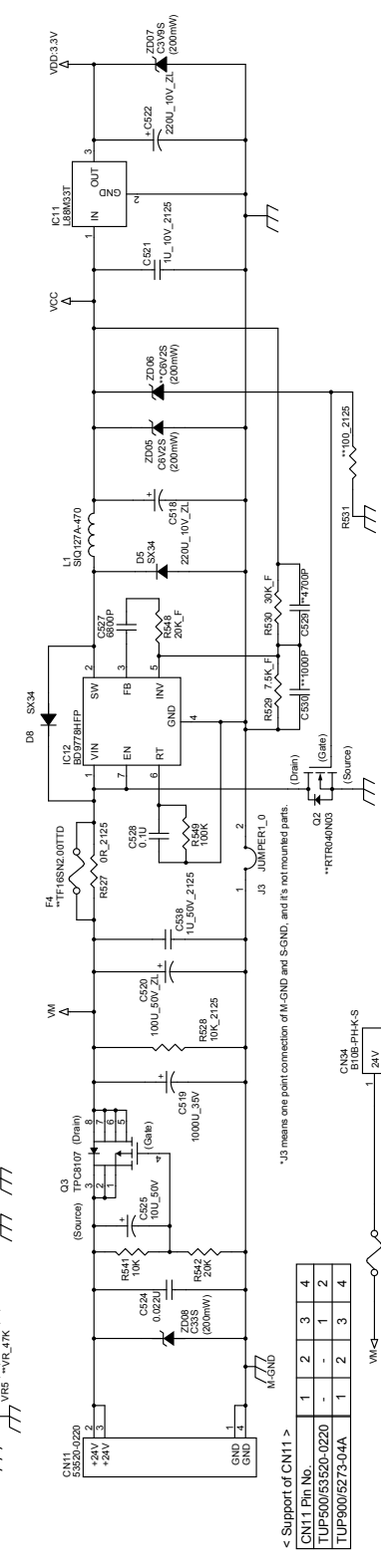
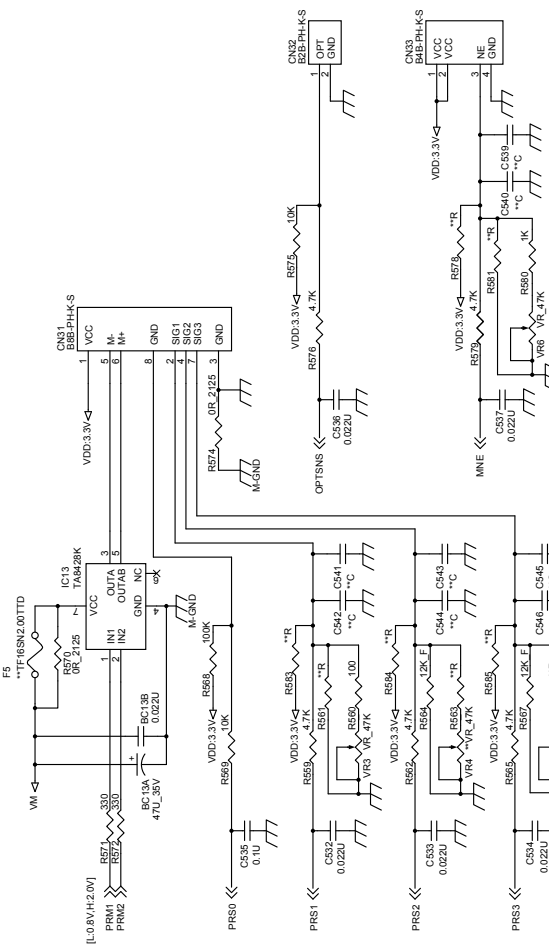
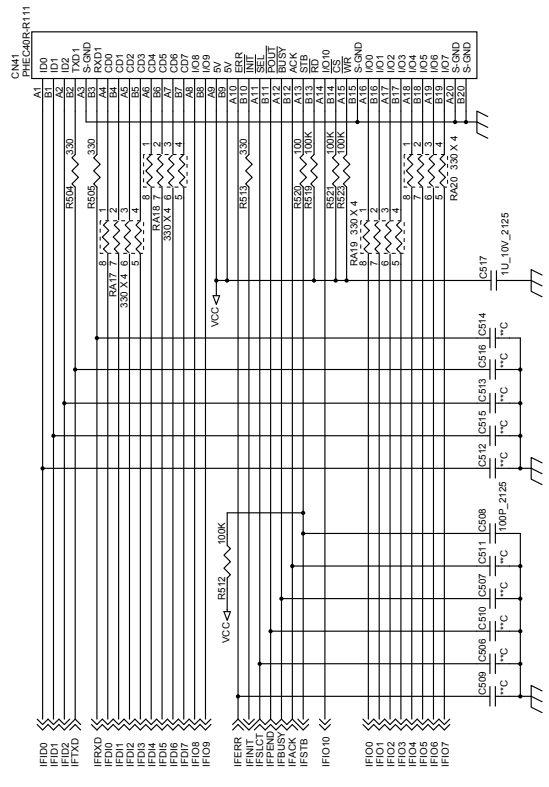

< Support of CN11 >

CN11 Pin No.	1	2	3	4
TUP500/53520-0220	-	-	1	2
TUP900/5273-04A	1	2	3	4

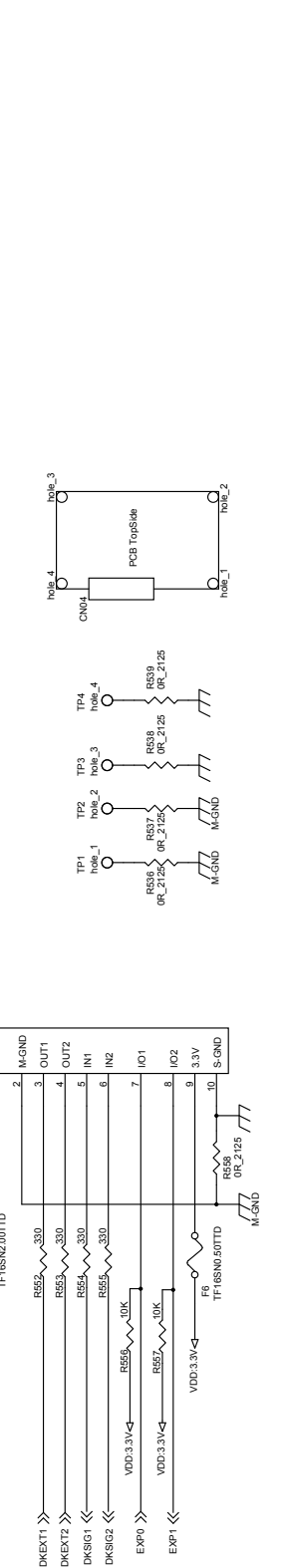

6-2. Component Layout

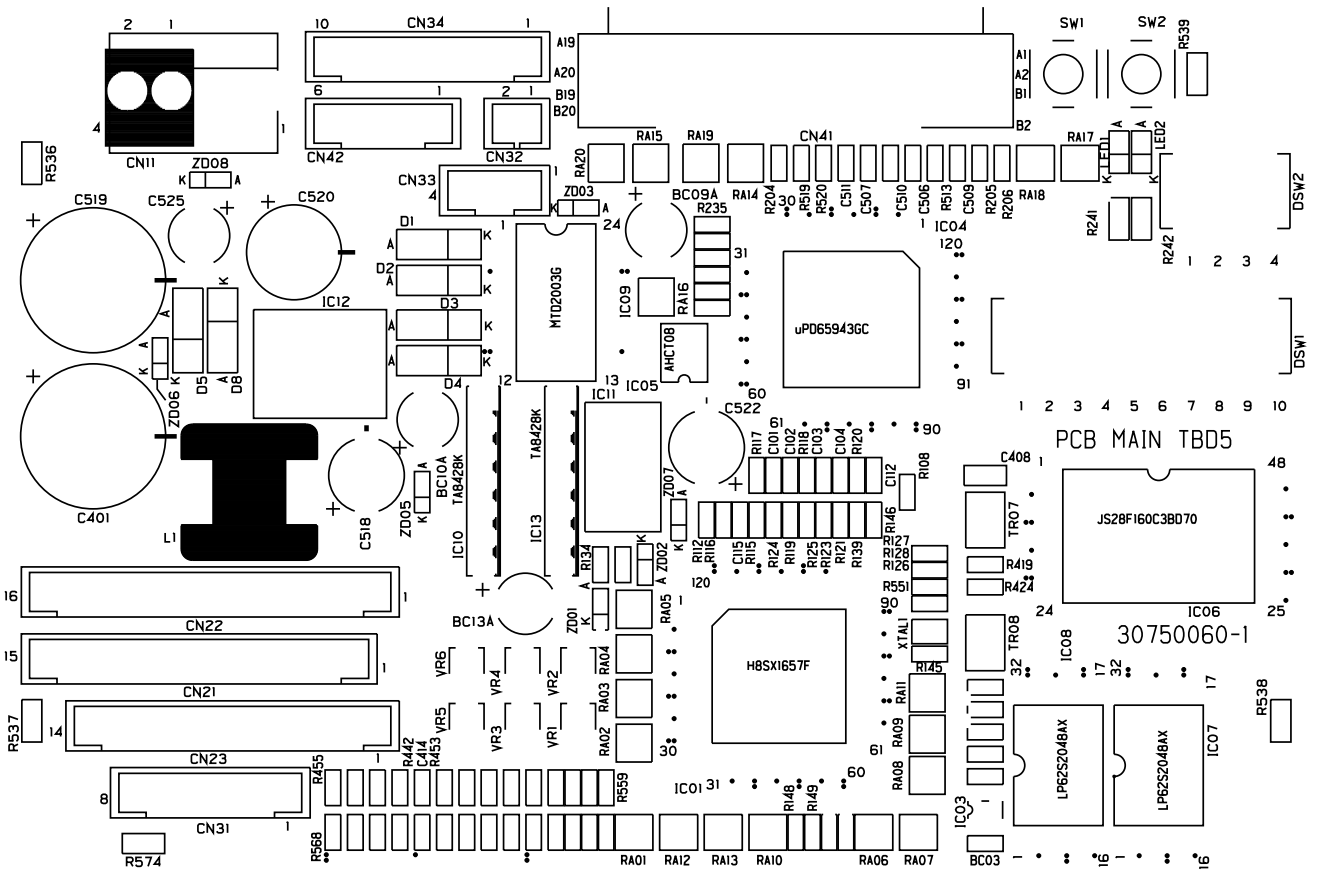

6-3. Circuit Number Diagram

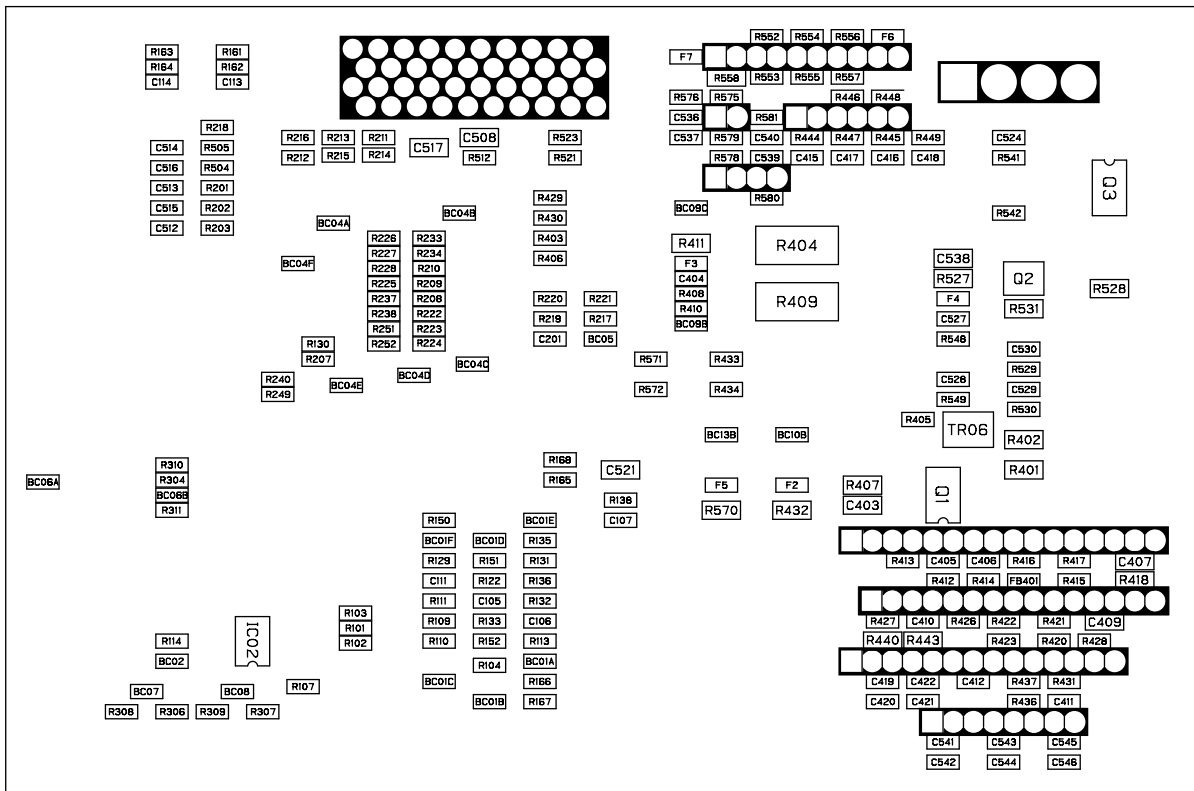
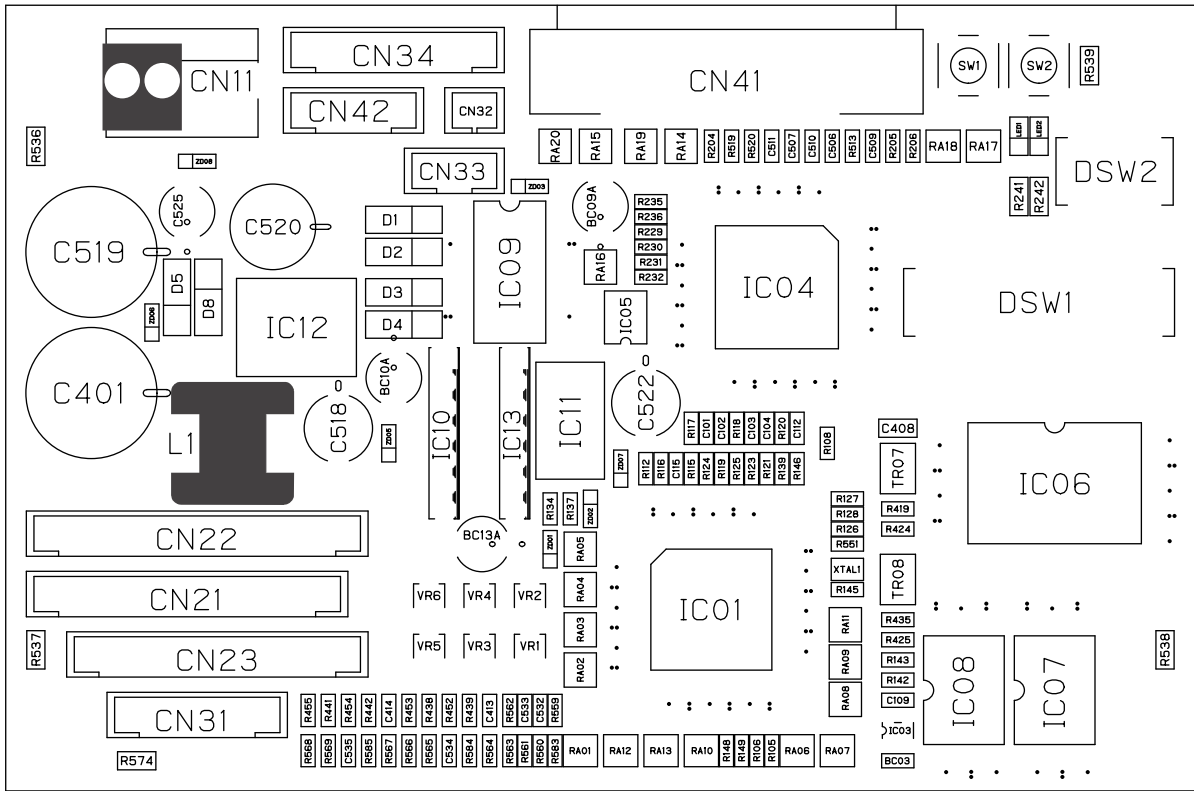

6-4. Parts List

Main Logic Board

DRWG.NO.	REV.	PARTS NO.	PARTS NAME	Q' TY	REMARKS	RANK
BC01A-01F		NPN	CERA.CAPA.CHIP1608 0.1UF 25V	6		
BC02-03		NPN	CERA.CAPA.CHIP1608 0.022UF 50V	2		
BC04A-04F		NPN	CERA.CAPA.CHIP1608 0.1UF 25V	6		
BC05		NPN	CERA.CAPA.CHIP1608 0.022UF 50V	1		
BC06A-08		NPN	CERA.CAPA.CHIP1608 0.1UF 25V	3		
BC09A		NPN	CHEM. CAPA. 47UF 35V	1		
BC09B-10A		NPN	CERA.CAPA.CHIP1608 0.022UF 50V	2		
BC10A		NPN	CHEM. CAPA. 47UF 35V	1		
BC10B		NPN	CERA.CAPA.CHIP1608 0.022UF 50V	1		
BC13A		NPN	CHEM. CAPA. 47UF 35V	1		
BC13B		NPN	CERA.CAPA.CHIP1608 0.022UF 50V	1		
C107		NPN	CERA.CAPA.CHIP1608 0.1UF 25V	1		
C109		NPN	CERA.CAPA.CHIP1608 1000PF 50V	1		
C111-112		NPN	CERA.CAPA.CHIP1608 0.1UF 25V	2		
C113-114		NPN	CERA.CAPA.CHIP1608 0.022UF 50V	2		
C115		NPN	CERA.CAPA.CHIP1608 27PF 50V	1		
C201		NPN	CERA. CAPA. CHIP 18PF 50V	1		
C401		NPN	CHEM. CAPA. 1000UF 35V	1		
C404		NPN	CERA.CAPA.CHIP1608 3900PF 50V	1		
C405-406		NPN	CERA. CAPA. CHIP 100PF 50V	2		
C406		NPN	CERA. CAPA. CHIP 100PF 50V	1		
C407-409		NPN	CERA. CAPA. CHIP 1UF 10V	3		
C410		NPN	CERA. CAPA. CHIP 100PF 50V	1		
C411		NPN	CERA.CAPA.CHIP1608 0.022UF 50V	1		
C412		NPN	CERA.CAPA.CHIP1608 0.1UF 25V	1		
C413-418		NPN	CERA.CAPA.CHIP1608 0.022UF 50V	6		
C508		NPN	CERA. CAPA. CHIP 100PF 50V	1		
C517		NPN	CERA. CAPA. CHIP 1UF 10V	1		
C518		NPN	CHEM. CAPA. 220UF 10V	1		
C519		NPN	CHEM. CAPA. 1000UF 35V	1		
C520		NPN	CHEM. CAPA. 100UF 50V	1		
C521		NPN	CERA. CAPA. CHIP 1UF 10V	1		
C522		NPN	CHEM. CAPA. 220UF 10V	1		
C524		NPN	CERA.CAPA.CHIP1608 0.022UF 50V	1		
C525		NPN	CHEM. CAPA. 10UF 50V	1		
C527		NPN	CERA.CAPA.CHIP1608 6800PF 50V	1		
C528		NPN	CERA.CAPA.CHIP1608 0.1UF 25V	1		
C532-534		NPN	CERA.CAPA.CHIP1608 0.022UF 50V	3		
C535		NPN	CERA.CAPA.CHIP1608 0.1UF 25V	1		
C536-537		NPN	CERA.CAPA.CHIP1608 0.022UF 50V	2		
C538		NPN	CERA. CAPA. CHIP 1UF 50V	1		
CN11		NPN	CONNECTOR 53520-0220	1		
CN21		NPN	CONNECTOR B15B-PH-K-S	1		
CN22		NPN	CONNECTOR B16B-PH-K-S	1		
CN23		NPN	CONNECTOR B14B-PH-K-S	1		
CN31		NPN	CONNECTOR B8B-PH-K	1		
CN32		NPN	CONNECTOR B2B-PH-K-S	1		
CN33		NPN	CONNECTOR B4B-PH-K-S	1		
CN34		NPN	CONNECTOR B10B-PH-K-S	1		
CN41		NPN	CONNECTOR PHEC40R-R111LF	1		
CN42		NPN	CONNECTOR B6B-PH-K-S(LF)(SN)	1		
D1-4		NPN	SCHOTTKY DIODE CHIP SS14*	4		
D5		NPN	SCHOTTKY DIODE CHIP SX34*	1		

Main Logic Board

DRWG.NO.	REV.	PARTS NO.	PARTS NAME	Q' TY	REMARKS	RANK
D8		NPN	SCHOTTKY DIODE CHIP SX34*	1		
DSW1		NPN	DIP SWITCH 219-10LPSTRF*	1		
DSW2		NPN	DIP SWITCH 219-04LPSTRF*	1		
F3		NPN	CHIP FUSE TF16SN315TTD*	1		
F6		NPN	CHIP FUSE TF16SN0.50TTD*	1		
F7		NPN	CHIP FUSE TF16SN200TTD*	1		
FB401		NPN	CHIP BEADS IND. BK1608HM601*	1		
IC01		NPN	CPU R5F61656CN35FTV	1	TB5 **	
IC02		NPN	EEPROM AT93C46DN-SH-T	1		
IC03		NPN	IC-RESET S-80130BN*	1		
IC04		NPN	GATE ARRAY UPD65943GC-TSPD	1		
IC05		NPN	CMOS SN74AHCT08PWR*EL	1		
IC06		NPN	FLASH MEMORY JS28F160C3BD70*	1	TB5#CH **	
IC07-08		NPN	SRAM LP62S2048AX55LLI*	2		
IC09		NPN	IC-MOTOR MTD2003G-3072*	1		
IC10		NPN	IC-MOTOR TA8428K	1		
IC11		NPN	IC-REG L88M33T*TL	1		
IC12		NPN	IC-REG BD9778HFP-E2*	1		
IC13		NPN	IC-MOTOR TA8428K	1		
L1		NPN	INDUCTOR SIQ127A-470*	1		
LED1		NPN	LED CHIP LT1E40A*	1		
LED2		NPN	LED CHIP LT1D40A*	1		
Q1		NPN	FET CHIP TPC8107*	1		
Q3		NPN	FET CHIP TPC8107*	1		
R101-103		NPN	CHIP RESISTOR 10 K-OHM 1/16W	3		
R104-106		NPN	CHIP RESISTOR 330 OHM 1/16W	3		
R107		NPN	CHIP RESISTOR 10 K-OHM 1/16W	1		
R108-111		NPN	CHIP RESISTOR 330 OHM 1/16W	4		
R113		NPN	CHIP RESISTOR 330 OHM 1/16W	1		
R114		NPN	CHIP RESISTOR 0 OHM 1/16W	1		
R115		NPN	CHIP RESISTOR 10 K-OHM 1/16W	1		
R116		NPN	CHIP RESISTOR 100 OHM 1/16W	1		
R117		NPN	CHIP RESISTOR 330 OHM 1/16W	1		
R118-121		NPN	CHIP RESISTOR 100 OHM 1/16W	4		
R122		NPN	CHIP RES1608 220 OHM 1/16W 5%	1		
R123-125		NPN	CHIP RESISTOR 10 K-OHM 1/16W	3		
R126-128		NPN	CHIP RESISTOR 330 OHM 1/16W	3		
R130		NPN	CHIP RES1608 220 OHM 1/16W 5%	1		
R131		NPN	CHIP RESISTOR 100 OHM 1/16W	1		
R132		NPN	CHIP RES1608 220 OHM 1/16W 5%	1		
R133		NPN	CHIP RESISTOR 10 K-OHM 1/16W	1		
R134		NPN	CHIP RESISTOR 20 K-OHM 1/16W	1		
R135-136		NPN	CHIP RESISTOR 10 K-OHM 1/16W	2		
R137		NPN	CHIP RESISTOR 4.7 K-OHM 1/16W	1		
R138		NPN	CHIP RESISTOR 1 K-OHM 1/16W	1		
R139		NPN	CHIP RESISTOR 330 OHM 1/16W	1		
R142-143		NPN	CHIP RES1608 1.5 KOHM 1/16W 5%	2		
R145		NPN	CHIP RESISTOR 0 OHM 1/16W	1		
R146		NPN	CHIP RESISTOR 100 OHM 1/16W	1		
R148-149		NPN	CHIP RESISTOR 10 K-OHM 1/16W	2		
R150-152		NPN	CHIP RESISTOR 1 K-OHM 1/16W	3		
R161		NPN	CHIP RESISTOR 10 K-OHM 1/16W	1		

Main Logic Board

DRWG.NO.	REV.	PARTS NO.	PARTS NAME	Q' TY	REMARKS	RANK
R162		NPN	CHIP RESISTOR 4.7 K-OHM 1/16W	1		
R163		NPN	CHIP RESISTOR 10 K-OHM 1/16W	1		
R164		NPN	CHIP RESISTOR 4.7 K-OHM 1/16W	1		
R165		NPN	CHIP RESISTOR 10 K-OHM 1/16W	1		
R166-167		NPN	CHIP RESISTOR 330 OHM 1/16W	2		
R168		NPN	CHIP RESISTOR 100 OHM 1/16W	1		
R201-207		NPN	CHIP RESISTOR 10 K-OHM 1/16W	7		
R207		NPN	CHIP RESISTOR 0 OHM 1/16W	1		
R208-210		NPN	CHIP RESISTOR 10 K-OHM 1/16W	3		
R211		NPN	CHIP RESISTOR 3.3 K-OHM 1/16W	1		
R212-213		NPN	CHIP RESISTOR 10 K-OHM 1/16W	2		
R214		NPN	CHIP RESISTOR 3.3 K-OHM 1/16W	1		
R215		NPN	CHIP RESISTOR 10 K-OHM 1/16W	1		
R216		NPN	CHIP RESISTOR 100 K-OHM 1/16W	1		
R217-218		NPN	CHIP RESISTOR 10 K-OHM 1/16W	2		
R219-220		NPN	CHIP RES1608 1.8 KOHM 1/16W 5%	2		
R221		NPN	CHIP RESISTOR 3.3 K-OHM 1/16W	1		
R222-238		NPN	CHIP RESISTOR 10 K-OHM 1/16W	17		
R241-242		NPN	CHIP RESISTOR 220 OHM 1/10W	2		
R249		NPN	CHIP RES1608 1.5 KOHM 1/16W 5%	1		
R251-252		NPN	CHIP RESISTOR 10 K-OHM 1/16W	2		
R304		NPN	CHIP RES1608 1.5 KOHM 1/16W 5%	1		
R308-309		NPN	CHIP RESISTOR 0 OHM 1/16W	2		
R311		NPN	CHIP RESISTOR 0 OHM 1/16W	1		
R401		NPN	CHIP RESISTOR 10 K-OHM 1/10W	1		
R402		NPN	CHIP RESISTOR 4.7 K-OHM 1/10W	1		
R403		NPN	CHIP RESISTOR 330 OHM 1/16W	1		
R404		NPN	CHIP RES6331 0.51 OHM 1W 1%	1		
R405-406		NPN	CHIP RESISTOR 330 OHM 1/16W	2		
R407		NPN	CHIP RESISTOR 10 K-OHM 1/10W	1		
R408		NPN	CHIP RESISTOR 15 K-OHM 1/16W	1		
R409		NPN	CHIP RES6331 0.51 OHM 1W 1%	1		
R412		NPN	CHIP RES1608 24 OHM 1/16W 5%	1		
R413		NPN	CHIP RESISTOR 10 K-OHM 1/16W	1		
R414		NPN	CHIP RESISTOR 100 OHM 1/16W	1		
R415-417		NPN	CHIP RESISTOR 1 K-OHM 1/16W	3		
R418		NPN	CHIP RESISTOR 0 OHM 1/10W	1		
R419		NPN	CHIP RESISTOR 10 K-OHM 1/16W	1		
R420		NPN	CHIP RESISTOR 15 K-OHM 1/16W	1		
R421-424		NPN	CHIP RESISTOR 1 K-OHM 1/16W	4		
R425		NPN	CHIP RESISTOR 33 K-OHM 1/16W	1		
R426		NPN	CHIP RESISTOR 1 K-OHM 1/16W	1		
R427		NPN	CHIP RES1608 24 OHM 1/16W 5%	1		
R428-429		NPN	CHIP RESISTOR 10 K-OHM 1/16W	2		
R430-431		NPN	CHIP RESISTOR 330 OHM 1/16W	2		
R432		NPN	CHIP RESISTOR 0 OHM 1/10W	1		
R433-434		NPN	CHIP RESISTOR 330 OHM 1/16W	2		
R435		NPN	CHIP RESISTOR 22 K-OHM 1/16W	1		
R436		NPN	CHIP RESISTOR 10 K-OHM 1/16W	1		
R437		NPN	CHIP RESISTOR 4.7 K-OHM 1/16W	1		
R439		NPN	CHIP RESISTOR 4.7 K-OHM 1/16W	1		
R440		NPN	CHIP RESISTOR 220 OHM 1/10W	1		

Main Logic Board

DRWG.NO.	REV.	PARTS NO.	PARTS NAME	Q' TY	REMARKS	RANK
R442		NPN	CHIP RESISTOR 4.7 K-OHM 1/16W	1		
R443		NPN	CHIP RESISTOR 220 OHM 1/10W	1		
R444-445		NPN	CHIP RESISTOR 100 OHM 1/16W	2		
R446		NPN	CHIP RESISTOR 10 K-OHM 1/16W	1		
R447		NPN	CHIP RESISTOR 4.7 K-OHM 1/16W	1		
R448		NPN	CHIP RESISTOR 10 K-OHM 1/16W	1		
R449		NPN	CHIP RESISTOR 4.7 K-OHM 1/16W	1		
R452		NPN	CHIP RESISTOR 100 OHM 1/16W	1		
R454		NPN	CHIP RESISTOR 100 OHM 1/16W	1		
R504-505		NPN	CHIP RESISTOR 330 OHM 1/16W	2		
R512		NPN	CHIP RESISTOR 100 K-OHM 1/16W	1		
R513		NPN	CHIP RESISTOR 330 OHM 1/16W	1		
R519		NPN	CHIP RESISTOR 100 K-OHM 1/16W	1		
R520		NPN	CHIP RESISTOR 100 OHM 1/16W	1		
R521		NPN	CHIP RESISTOR 100 K-OHM 1/16W	1		
R523		NPN	CHIP RESISTOR 100 K-OHM 1/16W	1		
R527		NPN	CHIP RESISTOR 0 OHM 1/10W	1		
R528		NPN	CHIP RESISTOR 10 K-OHM 1/10W	1		
R529		NPN	CHIP RES1608 7.5 KOHM 1/16W 1%	1		
R530		NPN	CHIP RES1608 30 KOHM 1/16W 1%	1		
R536-539		NPN	CHIP RESISTOR 0 OHM 1/10W	4		
R541		NPN	CHIP RESISTOR 10 K-OHM 1/16W	1		
R542		NPN	CHIP RES1608 20 KOHM 1/16W 5%	1		
R548		NPN	CHIP RESISTOR 20 K-OHM 1/16W	1		
R549		NPN	CHIP RESISTOR 100 K-OHM 1/16W	1		
R551		NPN	CHIP RESISTOR 10 K-OHM 1/16W	1		
R552-555		NPN	CHIP RESISTOR 330 OHM 1/16W	4		
R556-557		NPN	CHIP RESISTOR 10 K-OHM 1/16W	2		
R558		NPN	CHIP RESISTOR 0 OHM 1/10W	1		
R559		NPN	CHIP RESISTOR 4.7 K-OHM 1/16W	1		
R560		NPN	CHIP RESISTOR 100 OHM 1/16W	1		
R562		NPN	CHIP RESISTOR 4.7 K-OHM 1/16W	1		
R564		NPN	CHIP RES1608 12 KOHM 1/16W 1%	1		
R565		NPN	CHIP RESISTOR 4.7 K-OHM 1/16W	1		
R567		NPN	CHIP RES1608 12 KOHM 1/16W 1%	1		
R568		NPN	CHIP RESISTOR 100 K-OHM 1/16W	1		
R569		NPN	CHIP RESISTOR 10 K-OHM 1/16W	1		
R570		NPN	CHIP RESISTOR 0 OHM 1/10W	1		
R571-572		NPN	CHIP RESISTOR 330 OHM 1/16W	2		
R574		NPN	CHIP RESISTOR 0 OHM 1/10W	1		
R575		NPN	CHIP RESISTOR 10 K-OHM 1/16W	1		
R576		NPN	CHIP RESISTOR 4.7 K-OHM 1/16W	1		
R579		NPN	CHIP RESISTOR 4.7 K-OHM 1/16W	1		
R580		NPN	CHIP RESISTOR 1 K-OHM 1/16W	1		
RA01-09		NPN	RESIS. ARRAY CHIP MNR14J331*	9		
RA10		NPN	RESIS. ARRAY CHIP MNR14J103*	1		
RA11		NPN	RESIS. ARRAY CHIP MNR14J331*	1		
RA12-15		NPN	RESIS. ARRAY CHIP MNR14J103*	4		
RA16		NPN	RESIS. ARRAY CHIP MNR14J331*	5		
SW1-2		NPN	PUSH SWITCH SKHHAL	2		
TR06		NPN	DIGITAL TRANSISTOR KRC107S	1		
TR07		NPN	CHIP TRANSISTOR 2SA1362GR*85L	1		

Main Logic Board

DRWG.NO.	REV.	PARTS NO.	PARTS NAME	Q' TY	REMARKS	RANK
TR08		NPN	CHIP TRANSISTOR KTC3875S-G*AL	1		
VR1-2		NPN	RP CHIP RESISTOR EVM3S-68K	2		
VR3		NPN	RP CHIP RESISTOR EVM3S-47K	1		
VR6		NPN	RP CHIP RESISTOR EVM3S-47K	1		
XTAL1		NPN	CERA. OSC CHIP CSTCE16M0V53*	1		
ZD01		NPN	ZENER DIODE CHIP HZU20B2TRF	1		
ZD02		NPN	ZENER DIODE CHIP BZT52-C3V9S*	1		
ZD03		NPN	ZENER DIODE CHIP BZT52-C33S*	1		
ZD05		NPN	ZENER DIODE CHIP BZT52-C6V2S*	1		
ZD07		NPN	ZENER DIODE CHIP BZT52-C3V9S*	1		
ZD08		NPN	ZENER DIODE CHIP BZT52-C33S*	1		
-		NPN	FLASH MEMORY SEAL KEI-801	2		

7. Sub Board

7-1. Circuit Diagram

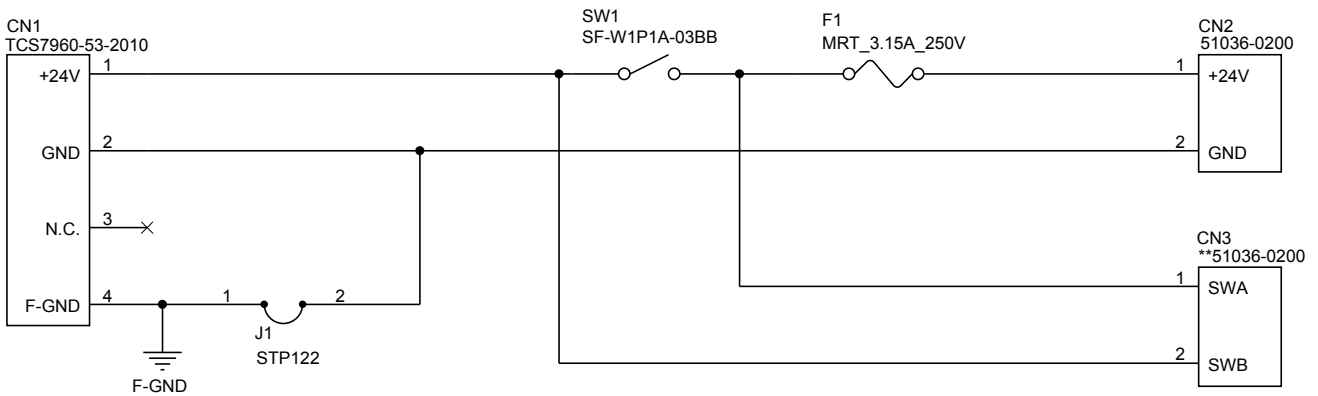

The part marked with two asterisks (**) is not mounted.
部品の名称に「**」の付いたものは未装着

7-2. Component Layout

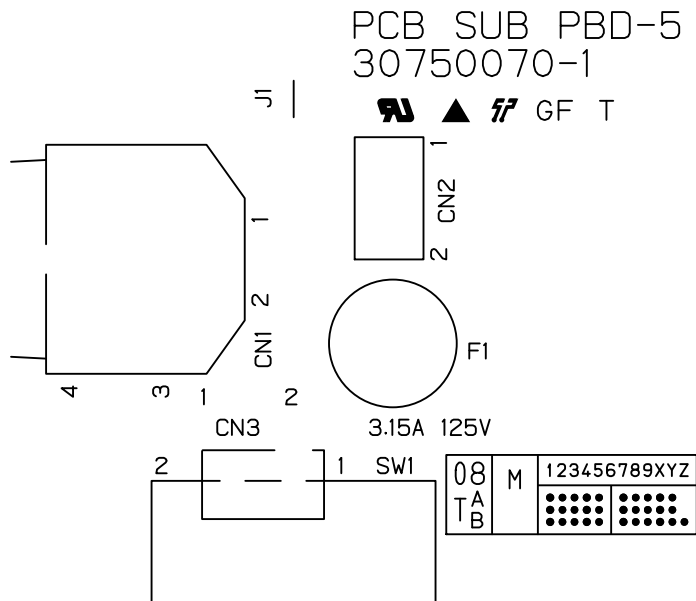

7-3. Parts List

Sub Board						
DRWG.NO.	REV.	PARTS NO.	PARTS NAME	Q' TY	REMARKS	RANK
CN1		NPN	CONNECTOR TCS7960-53-2010	1		
CN2		NPN	CABLE UNIT 2X60CC TSP8	1		
F1		NPN	FUSE MRT3.15A-250V*	1		
J1		NPN	JUMPER WIRE STP122	1		
SW1		NPN	SEESAW SWITCH SF-W1P1A03BB	1		

8. Control Panel Board

8-1. Circuit Diagram

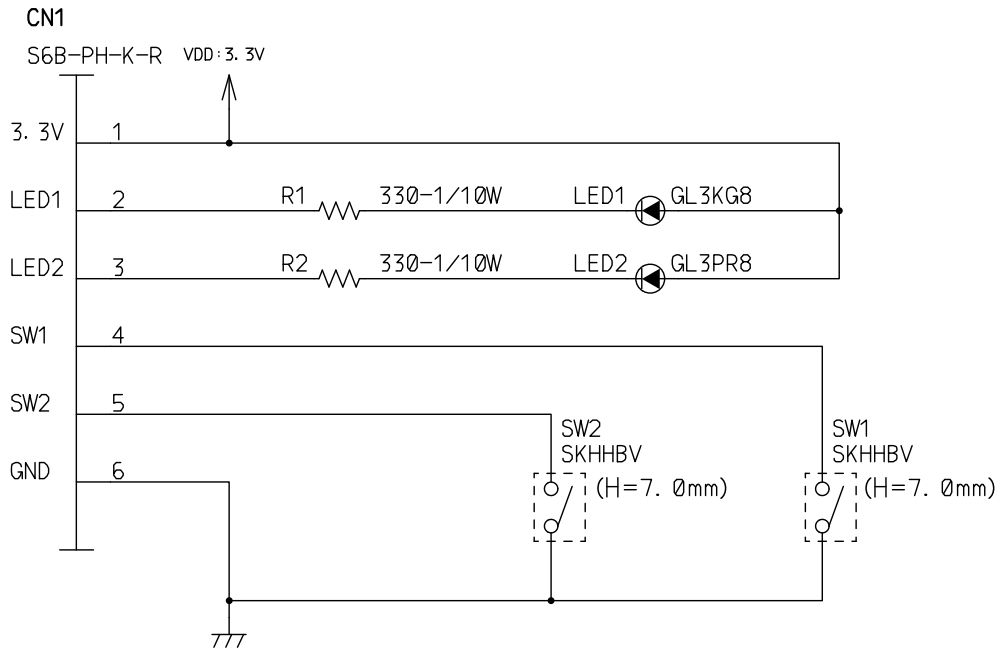

8-2. Component Layout

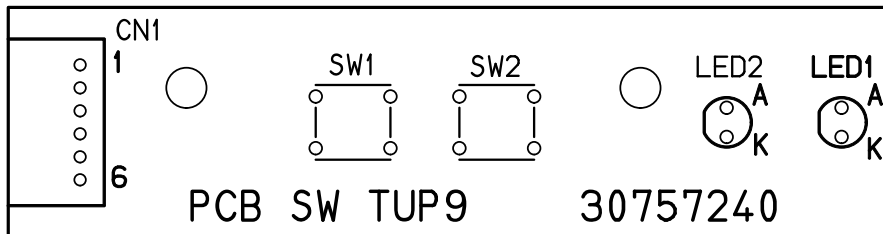

8-3. Parts List

Control Panel Board

DRWG.NO.	REV.	PARTS NO.	PARTS NAME	Q' TY	REMARKS	RANK
CN1		NPN	CONNECTOR S6B-PH-K-R	1		
LED1		NPN	LED GL3KG8	1		
LED2		NPN	LED GL3PR8	1		
R1-2		NPN	CHIP RESISTOR 330 OHM 1/10W	2		
SW1-2		NPN	PUSH SWITCH SKHHBV	2		
-		NPN	CABLE UNIT 6X220CC TUP9	1		

9. Snout Board

9-1. Circuit Diagram

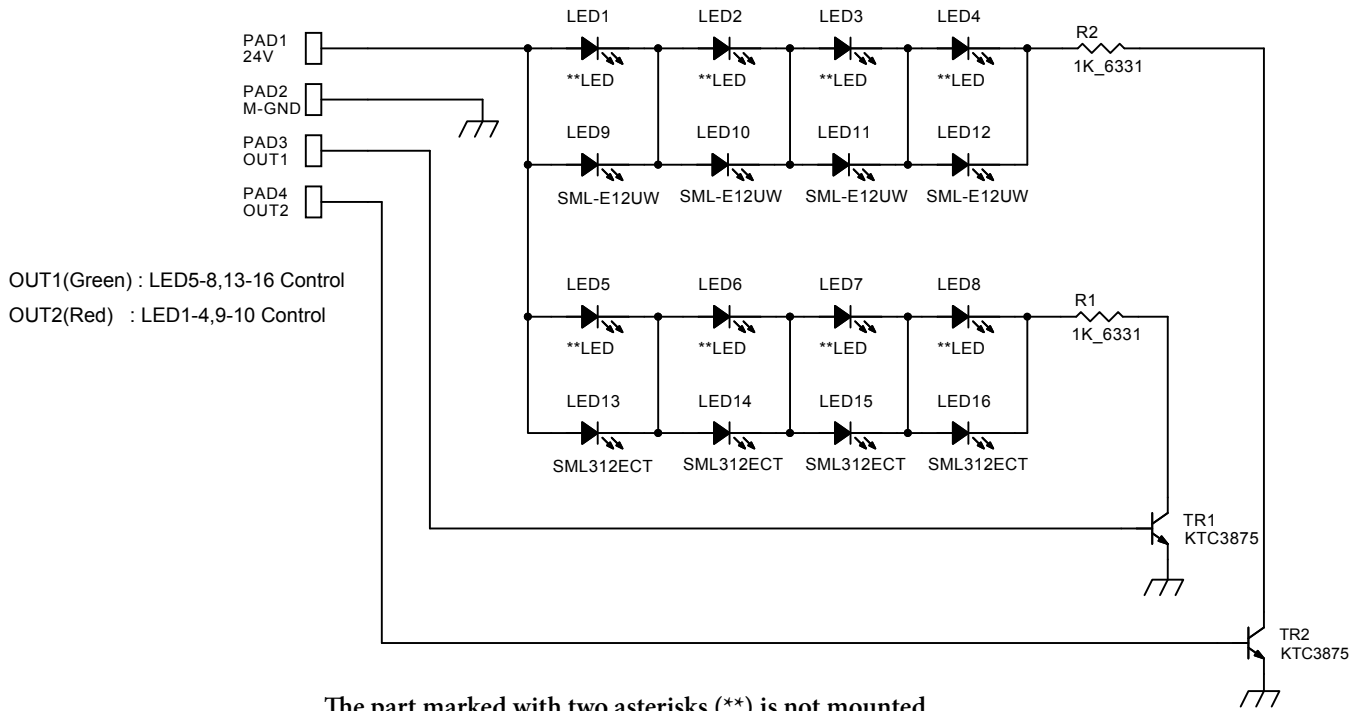

9-2. Component Layout

PCB SNOOT TUP5 30758500

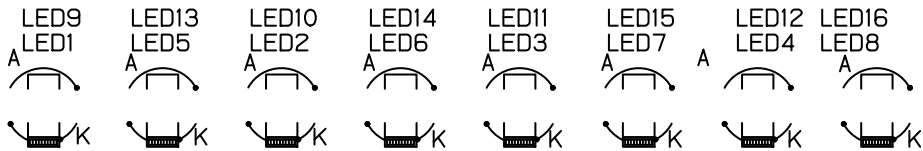

9-3. Parts List

Snout Board

DRWG.NO.	REV.	PARTS NO.	PARTS NAME	Q' TY	REMARKS	RANK
LED9-12		08300220	LED CHIP SML-E12UW*	4		
LED13-16		08300221	LED CHIP SML312ECT*	4		
R1-2		06711022	CHIP RES6331 1 KOHM 1W 5%	2		
TR1-2		07238755	CHIP TRANSISTOR KTC3875S-G*AL	2		
-		30723230	CABLE UNIT 4X300C TUP5	1		

10. Serial Interface Board (25pin)

10-1. Circuit Diagram

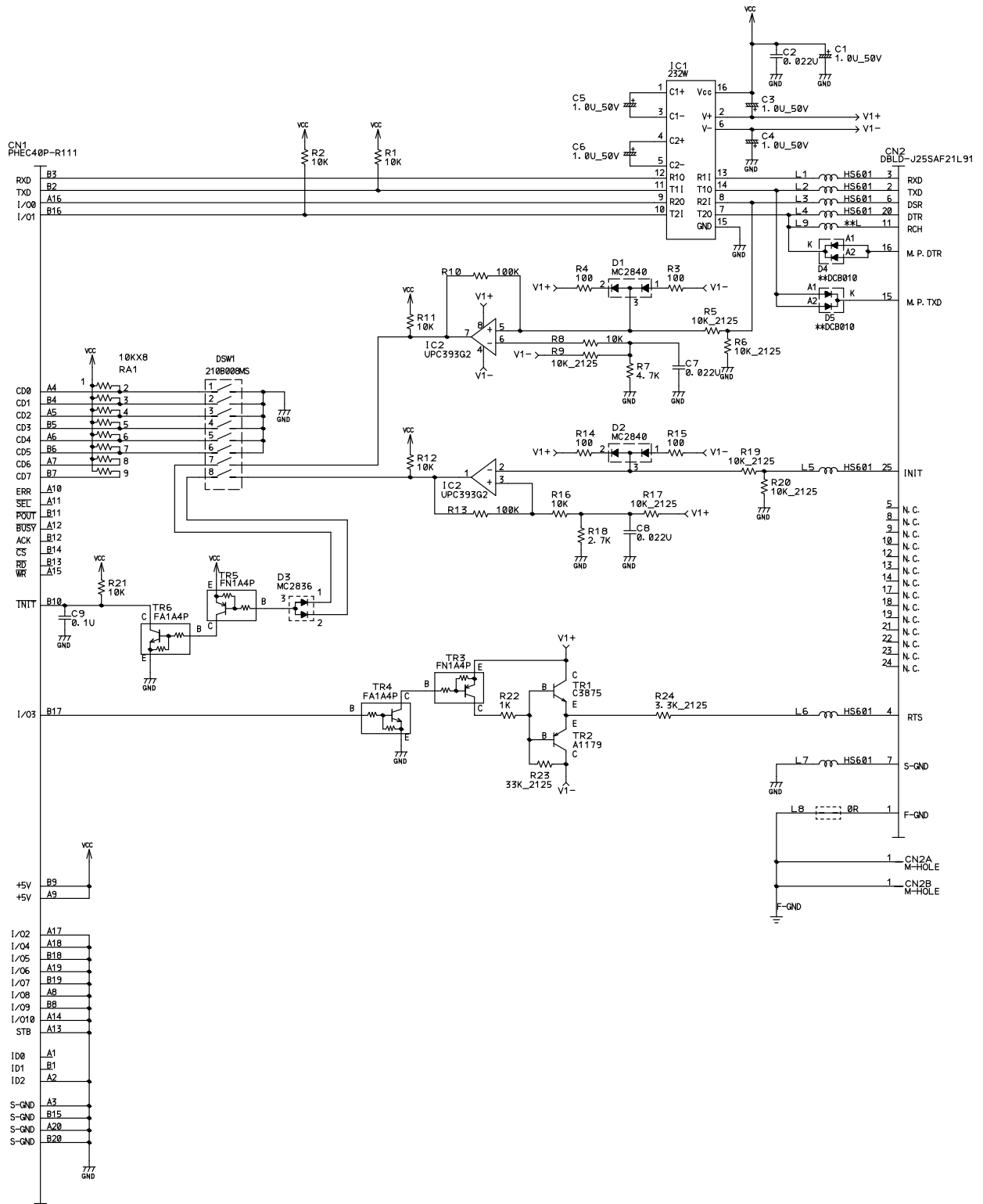

10-2. Parts List

Serial Interface Board (25pin)

DRWG.NO.	REV.	PARTS NO.	PARTS NAME	Q' TY	REMARKS	RANK
C1		NPN	CHEM. CAPA. 1UF 50V	1		
C2		NPN	CERA.CAPA.CHIP1608 0.022UF 50V	1		
C3-6		NPN	CHEM. CAPA. 1UF 50V	4		
C7-8		NPN	CERA.CAPA.CHIP1608 0.022UF 50V	2		
C9		NPN	CERA.CAPA.CHIP1608 0.1UF 25V	1		
CN1		NPN	CONNECTOR PHEC40P-R111LF	1		
CN2		NPN	CONNECTOR DBLD-J25SAF-21L9-1	1		
D1-2		NPN	DIODE CHIP BAT54S*	2		
D3		NPN	DIODE CHIP MC2836	1		
D4-5					NOT MOUNTED	
DSW1		NPN	DIP SWITCH 210B008MS	1		
IC1		08200208	IC-I/F ST232ECWR*	1		S
IC2		NPN	IC-LIN UPC393G2*T1	1		
L1-7		NPN	CHIP BEADS IND. BK1608HS601*	7		
L8		NPN	CHIP RESISTOR 0 OHM 1/16W	1		
L9					NOT MOUNTED	
R1-2		NPN	CHIP RESISTOR 10 K-OHM 1/16W	2		
R3-4		NPN	CHIP RESISTOR 100 OHM 1/16W	2		
R5-6		NPN	CHIP RESISTOR 10 K-OHM 1/10W	2		
R7		NPN	CHIP RESISTOR 4.7 K-OHM 1/16W	1		
R8		NPN	CHIP RESISTOR 10 K-OHM 1/16W	1		
R9		NPN	CHIP RESISTOR 10 K-OHM 1/10W	1		
R10		NPN	CHIP RESISTOR 100 K-OHM 1/16W	1		
R11-12		NPN	CHIP RESISTOR 10 K-OHM 1/16W	2		
R13		NPN	CHIP RESISTOR 100 K-OHM 1/16W	1		
R14-15		NPN	CHIP RESISTOR 100 OHM 1/16W	2		
R16		NPN	CHIP RESISTOR 10 K-OHM 1/16W	1		
R17		NPN	CHIP RESISTOR 10 K-OHM 1/10W	1		
R18		NPN	CHIP RES1608 2.7 KOHM 1/16W 5%	1		
R19-20		NPN	CHIP RESISTOR 10 K-OHM 1/10W	2		
R21		NPN	CHIP RESISTOR 10 K-OHM 1/16W	1		
R22		NPN	CHIP RESISTOR 1 K-OHM 1/16W	1		
R23		NPN	CHIP RESISTOR 33 K-OHM 1/10W	1		
R24		NPN	CHIP RESISTOR 3.3 K-OHM 1/10W	1		
RA1		NPN	RESIS. ARRAY 10 K-OHM 1/8W 8EL	1		
TR1		NPN	CHIP TRANSISTOR KTC3875S-G*AL	1		
TR2		NPN	CHIP TRANSISTOR 2SA1179M6-STR	1		
TR3		NPN	DIGITAL TRANSISTOR FN1A4P	1		
TR4		NPN	DIGITAL TRANSISTOR FA1A4P	1		
TR5		NPN	DIGITAL TRANSISTOR FN1A4P	1		
TR6		NPN	DIGITAL TRANSISTOR FA1A4P	1		

11. Serial Interface Board (9pin)

11-1. Circuit Diagram

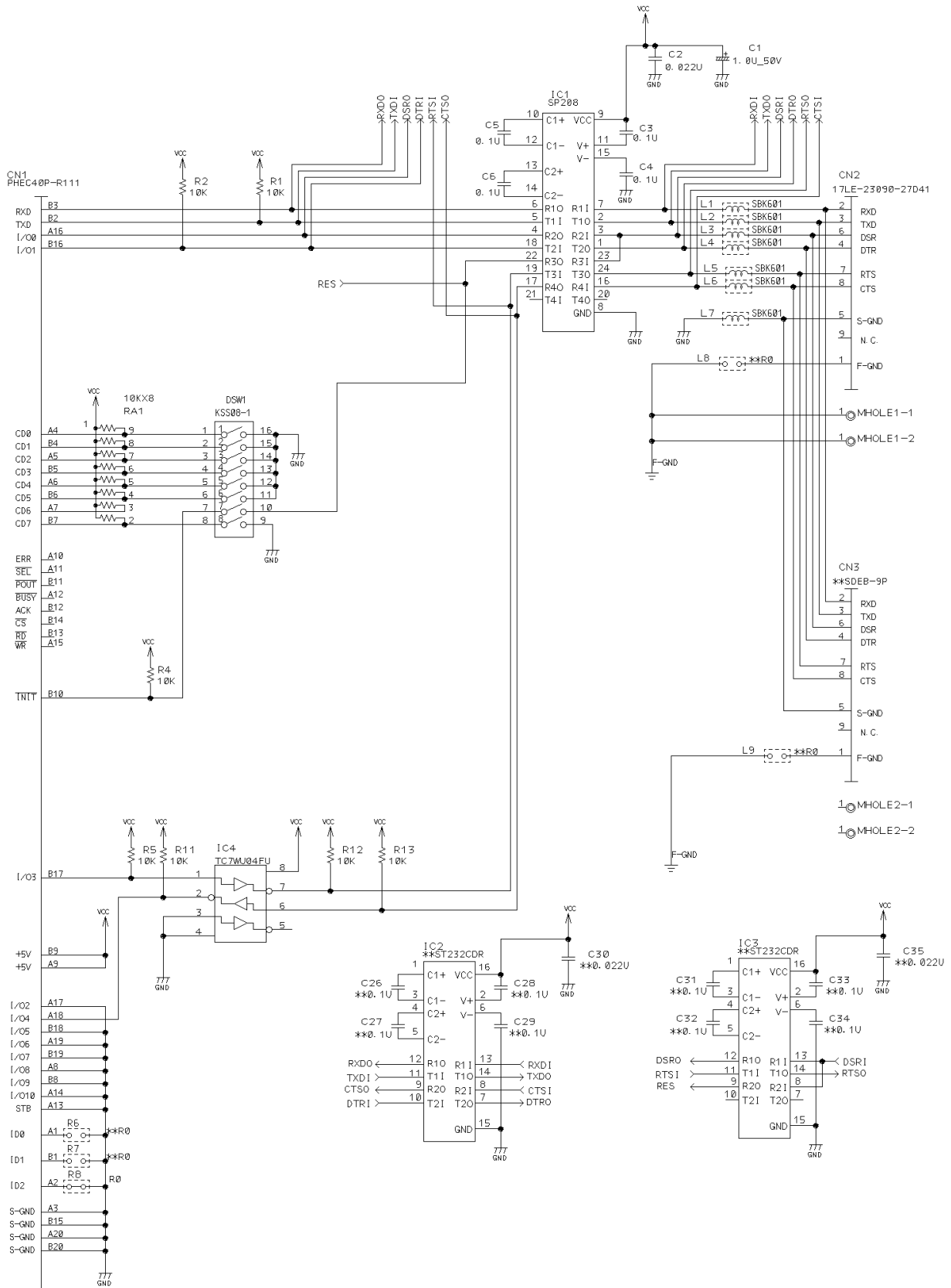

11-2. Parts List

Serial Interface Board (9pin)

DRWG.NO.	REV.	PARTS NO.	PARTS NAME	Q' TY	REMARKS	RANK
C1		NPN	CHEM. CAPA. 1UF 50V	1		
C2		NPN	CERA.CAPA.CHIP1608 0.022UF 50V	1		
C3-6		NPN	CERA.CAPA.CHIP1608 0.1UF 25V	4		
C26-35					NOT MOUNTED	
R1-2		NPN	CHIP RESISTOR 10 K-OHM 1/16W	2		
R4-5		NPN	CHIP RESISTOR 10 K-OHM 1/16W	2		
R6-7					NOT MOUNTED	
R8		NPN	CHIP RESISTOR 0 OHM 1/16W	1		
R11-13		NPN	CHIP RESISTOR 10 K-OHM 1/16W	3		
RA1		NPN	RESIS. ARRAY 10 K-OHM 1/8W 8EL	1		
IC1		08200213	IC-I/F HIN208EIAZ-T*	1		S
IC2-3					NOT MOUNTED	
IC4		NPN	CMOS TC7WU04FU*12L	1		
L1-7		NPN	CHIP BEADS IND. BK1608HS601*	7		
L8-9					NOT MOUNTED	
DSW1		NPN	DIP SWITCH 210B008MS	1		
CN1		NPN	CONNECTOR PHEC40P-R111LF	1		
CN2		NPN	CONNECTOR 17LE-23090-27D41	1		
CN3					NOT MOUNTED	

12. Parallel Interface Board

12-1. Circuit Diagram

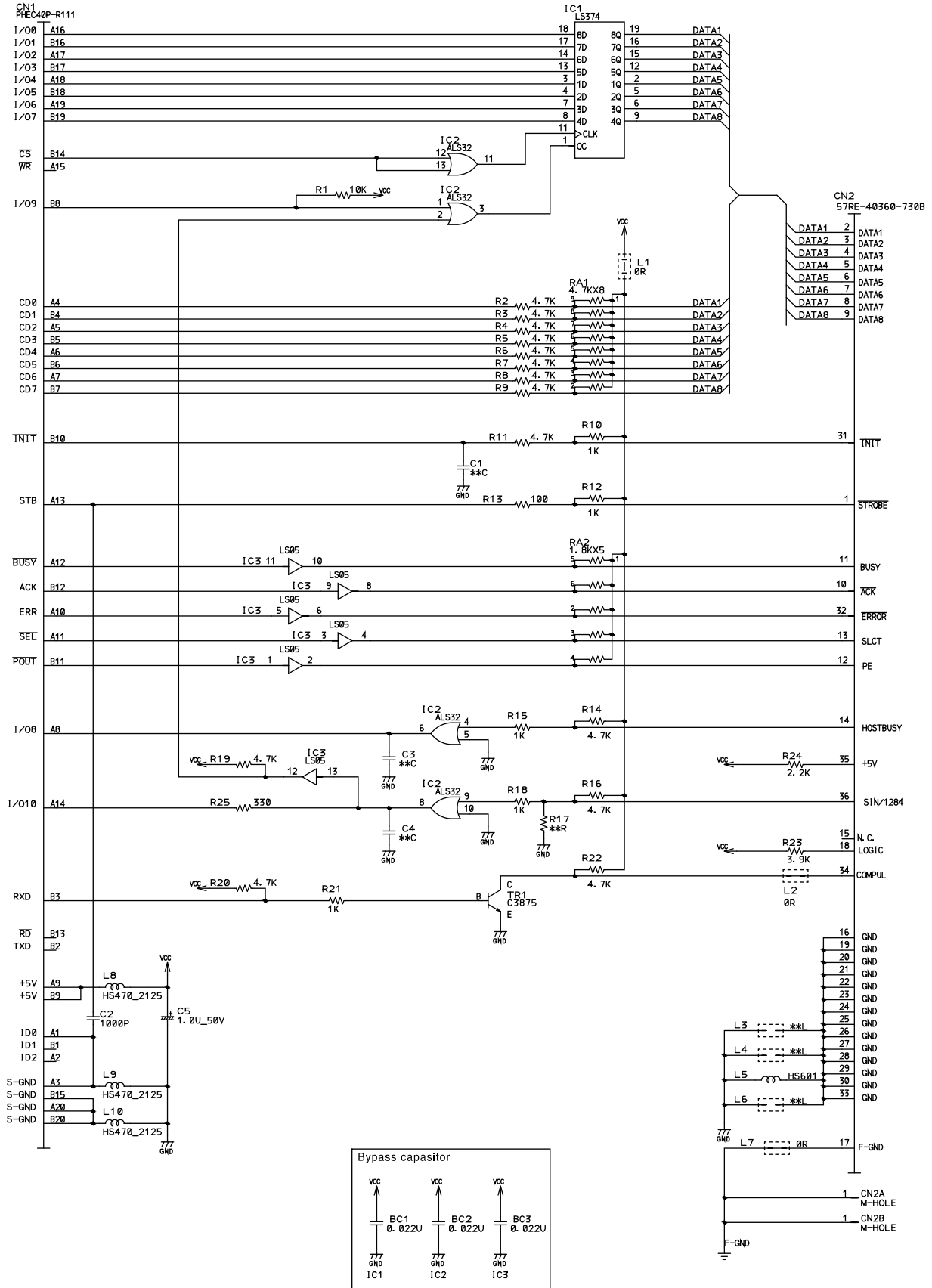

12-2. Parts List

Parallel Interface Board

DRWG.NO.	REV.	PARTS NO.	PARTS NAME	Q' TY	REMARKS	RANK
BC1-3		NPN	CERA.CAPA.CHIP1608 0.022UF 50V	3		
C1					NOT MOUNTED	
C2		NPN	CERA.CAPA.CHIP1608 1000PF 50V	1		
C3-4					NOT MOUNTED	
C5		NPN	CHEM. CAPA. 1UF 50V	1		
CN1		NPN	CONNECTOR PHEC40P-R111LF	1		
CN2		NPN	CONNECTOR 57RE-40360-830BD29A	1		
IC1		08211042	TTL IC 74LS374NSR*EL	1		S
IC2		NPN	TTL IC 74ALS32FP*EL	1		
IC3		08210126	TTL IC 74LS05FP*EL	1		S
L1-2		NPN	CHIP RESISTOR 0 OHM 1/16W	2		
L3-6		09990754	CHIP BEADS IND. BK1608HS601*	4		S
L7		NPN	CHIP RESISTOR 0 OHM 1/16W	1		
L8-10		NPN	CHIP BEADS IND. BK2125HS470*	3		
R1		NPN	CHIP RESISTOR 10 K-OHM 1/16W	1		
R2-9		NPN	CHIP RESISTOR 4.7 K-OHM 1/16W	8		
R10		NPN	CHIP RESISTOR 1 K-OHM 1/16W	1		
R11		NPN	CHIP RESISTOR 4.7 K-OHM 1/16W	1		
R12		NPN	CHIP RESISTOR 1 K-OHM 1/16W	1		
R13		NPN	CHIP RESISTOR 100 OHM 1/16W	1		
R14		NPN	CHIP RESISTOR 4.7 K-OHM 1/16W	1		
R15		NPN	CHIP RESISTOR 1 K-OHM 1/16W	1		
R16		NPN	CHIP RESISTOR 4.7 K-OHM 1/16W	1		
R17					NOT MOUNTED	
R18		NPN	CHIP RESISTOR 1 K-OHM 1/16W	1		
R19-20		NPN	CHIP RESISTOR 4.7 K-OHM 1/16W	2		
R21		NPN	CHIP RESISTOR 1 K-OHM 1/16W	1		
R22		NPN	CHIP RESISTOR 4.7 K-OHM 1/16W	1		
R23		NPN	CHIP RES1608 3.9 KOHM 1/16W 5%	1		
R24		NPN	CHIP RESISTOR 2.2 K-OHM 1/16W	1		
R25		NPN	CHIP RESISTOR 330 OHM 1/16W	1		
RA1		NPN	RESIS. ARRAY 4.7K-OHM 1/8W 8EL	1		
RA2		NPN	RESIS. ARRAY 1.8K-OHM 1/8W 5EL	1		
TR1		NPN	CHIP TRANSISTOR KTC3875S-G*AL	1		

13. USB Interface Board

13-1. Circuit Diagram

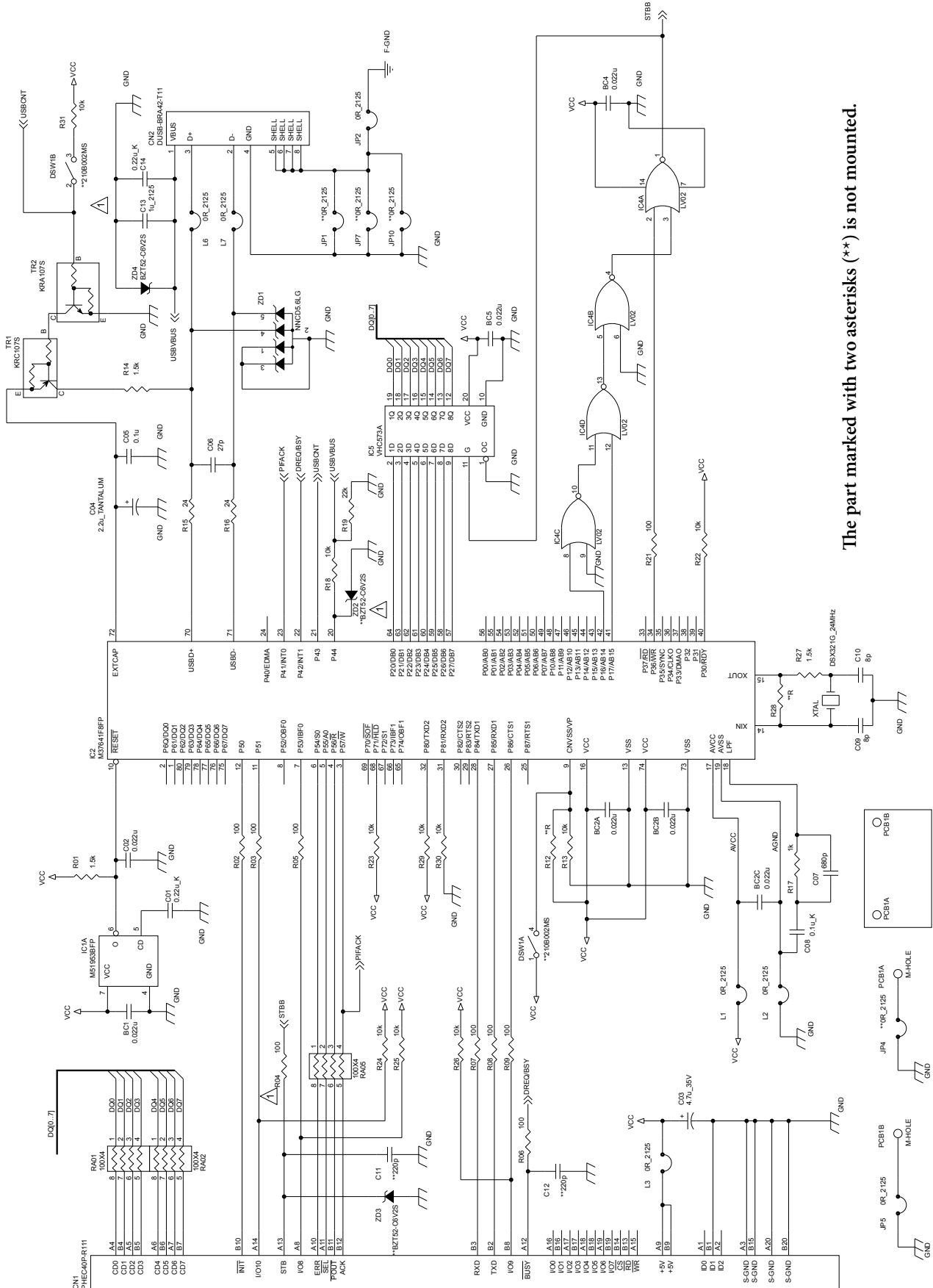

The part marked with two asterisks (***) is not mounted.

13-2. Component Layout

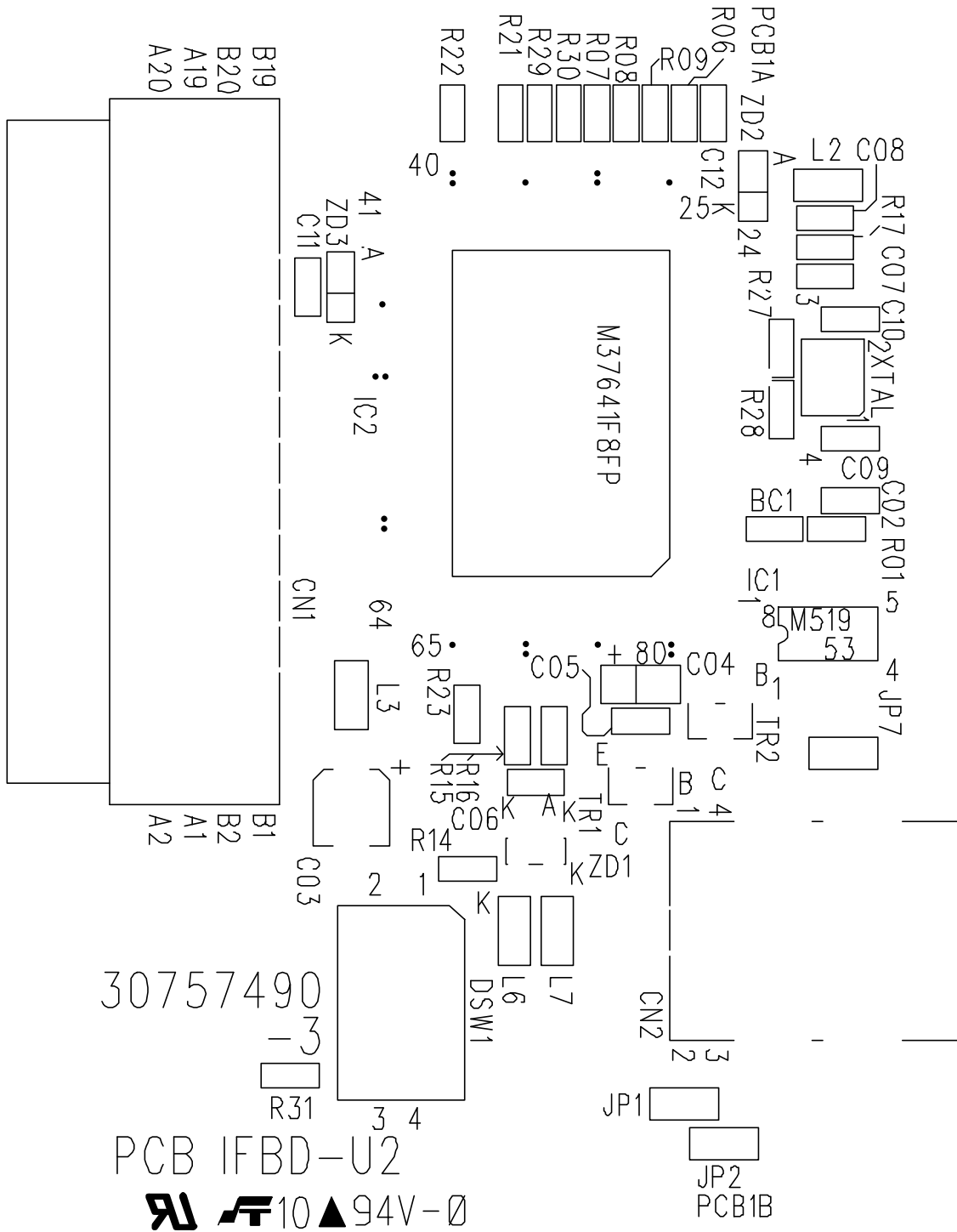

13-3. Parts List

USB Interface Board

DRWG.NO.	REV.	PARTS NO.	PARTS NAME	Q' TY	REMARKS	RANK
BC1		NPN	CERA.CAPA.CHIP1608 0.022UF 50V	1		
BC2A		NPN	CERA.CAPA.CHIP1608 0.022UF 50V	1		
BC2B		NPN	CERA.CAPA.CHIP1608 0.022UF 50V	1		
BC2C		NPN	CERA.CAPA.CHIP1608 0.022UF 50V	1		
BC4-5		NPN	CERA.CAPA.CHIP1608 0.022UF 50V	2		
C01		NPN	CERA.CAPA.CHIP1608 0.22UF 10V	1		
C02		NPN	CERA.CAPA.CHIP1608 0.022UF 50V	1		
C03		NPN	CHEM. CAPA. CHIP 4.7UF 35V	1		
C04		NPN	TANTALUM CAPA. CHIP 2.2UF 16V	1		
C05		NPN	CERA.CAPA.CHIP1608 0.1UF 25V	1		
C06		NPN	CERA.CAPA.CHIP1608 27PF 50V	1		
C07		NPN	CERA.CAPA.CHIP1608 680PF 50V	1		
C08		NPN	CERA.CAPA.CHIP1608 0.1UF 16V	1		
C09-10		NPN	CERA.CAPA.CHIP1608 8PF 50V	2		
C13		NPN	CERA. CAPA. CHIP 1UF 10V	1		
C14		NPN	CERA.CAPA.CHIP1608 0.22UF 10V	1		
CN1		NPN	CONNECTOR PHEC40P-R111LF	1		
CN2		NPN	CONNECTOR DUSB-BRA42-T11	1		
IC1		NPN	IC-RESET M51953BFP*E2	1		
IC2		NPN	CPU M37641F8FP	1		
IC4		NPN	CMOS 74LV02AFP*EL	1		
IC5		NPN	CMOS 74VHC573F*EL	1		
		NPN	FLASH MEMORY SEAL KEI-801	1		
JP2		NPN	CHIP RESISTOR 0 OHM 1/10W	1		
JP5		NPN	CHIP RESISTOR 0 OHM 1/10W	1		
L1-3		NPN	CHIP RESISTOR 0 OHM 1/10W	3		
L6-7		NPN	CHIP RESISTOR 0 OHM 1/10W	2		
R01		NPN	CHIP RES1608 1.5 KOHM 1/16W 5%	1		
R02-09		NPN	CHIP RESISTOR 100 OHM 1/16W	8		
R13		NPN	CHIP RESISTOR 10 K-OHM 1/16W	1		
R14		NPN	CHIP RES1608 1.5 KOHM 1/16W 5%	1		
R15-16		NPN	CHIP RES1608 24 OHM 1/16W 5%	2		
R17		NPN	CHIP RESISTOR 1 K-OHM 1/16W	1		
R18		NPN	CHIP RESISTOR 10 K-OHM 1/16W	1		
R19		NPN	CHIP RESISTOR 22 K-OHM 1/16W	1		
R21		NPN	CHIP RESISTOR 100 OHM 1/16W	1		
R22-26		NPN	CHIP RESISTOR 10 K-OHM 1/16W	5		
R27		NPN	CHIP RES1608 1.5 KOHM 1/16W 5%	1		
R29-31		NPN	CHIP RESISTOR 10 K-OHM 1/16W	3		
RA01		NPN	RESIS. ARRAY CHIP MNR14J101*	1		
RA02		NPN	RESIS. ARRAY CHIP MNR14J101*	1		
RA05		NPN	RESIS. ARRAY CHIP MNR14J101*	1		
TR1		NPN	DIGITAL TRANSISTOR KRA107S	1		
TR2		NPN	DIGITAL TRANSISTOR KRC107S	1		
XTAL		NPN	CRYSTAL CHIP DSX321G 24MHZ	1		
ZD1		NPN	ZENER DIODE CHIP NNCD5.6LG*T1	1		
ZD4		NPN	ZENER DIODE CHIP BZT52-C6V2S*	1		
-		NPN	BAR CODE LABEL LBP-80141	1		

14. Ethernet Interface Board

14-1. Circuit Diagram

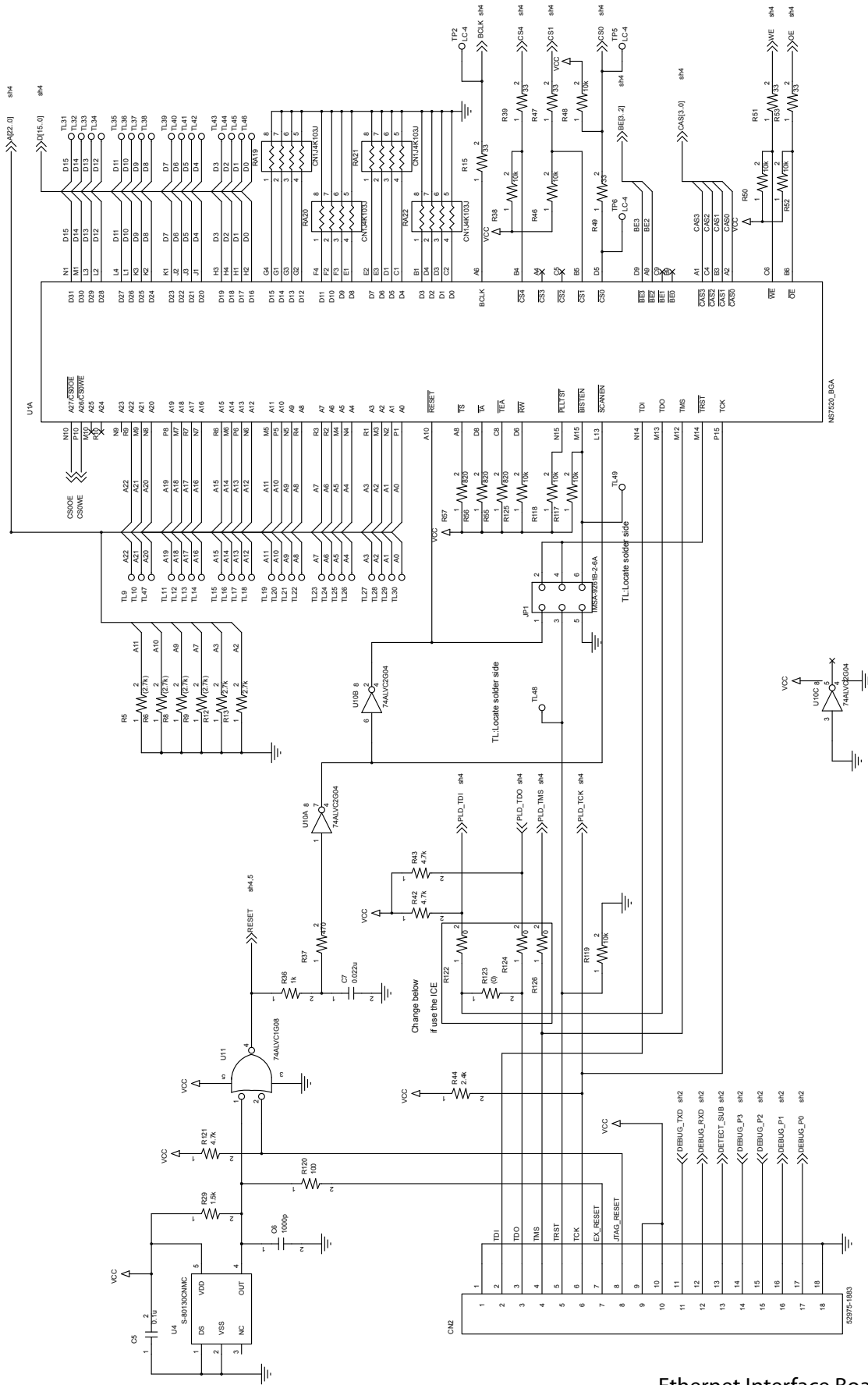

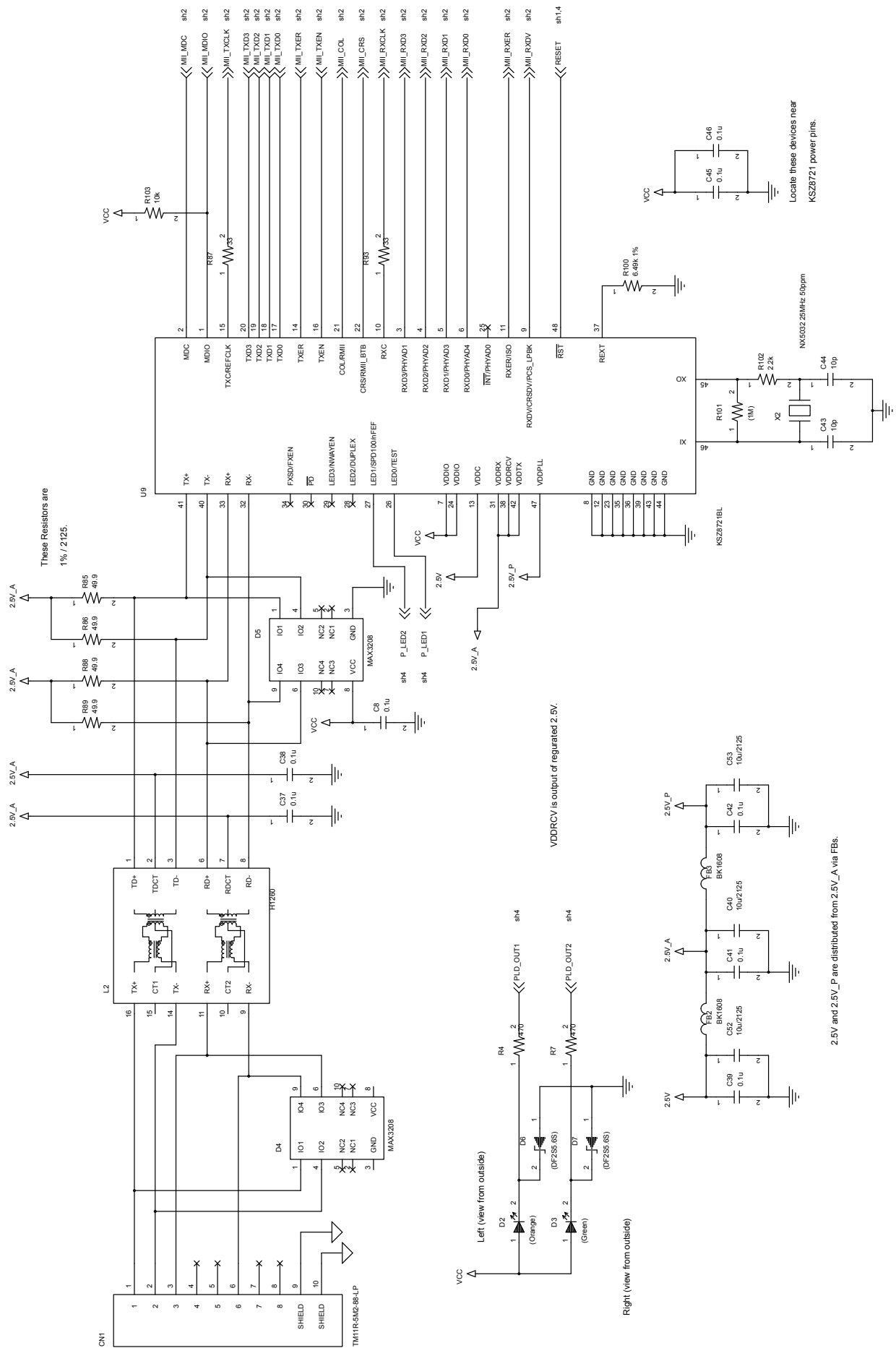

These Resistors are 1% / 2125.

VDDRCV is output of regulated 2.5V.

2.5V and 2.5V_P are distributed from 2.5V_A via FBs.

Locate these devices near KSZ8721 power pins.

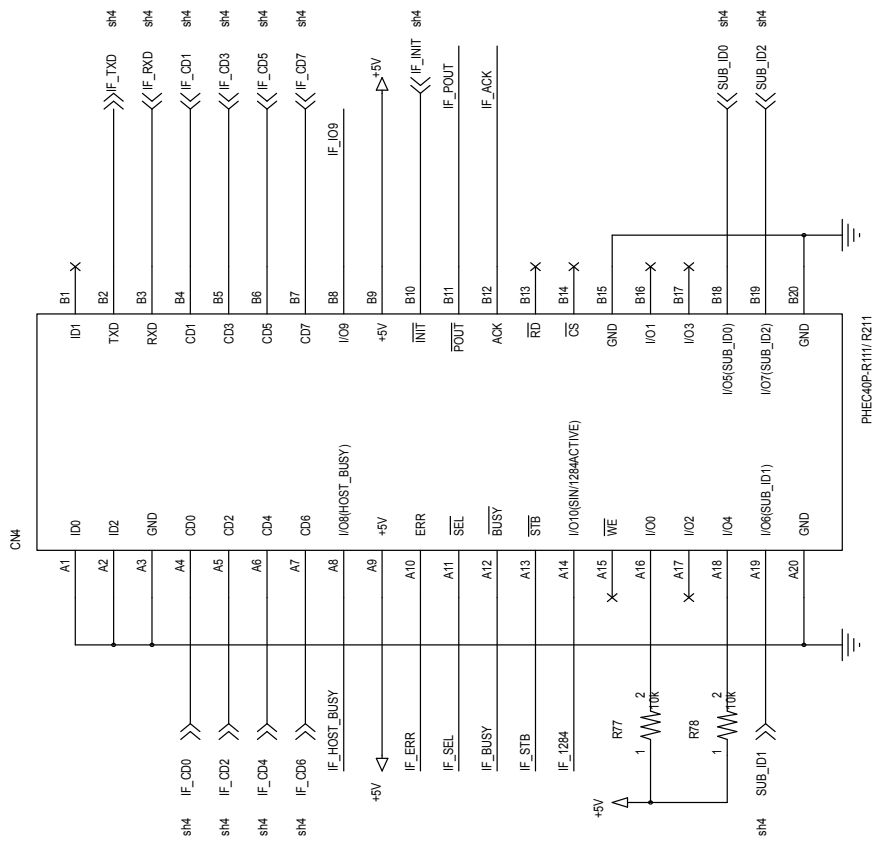
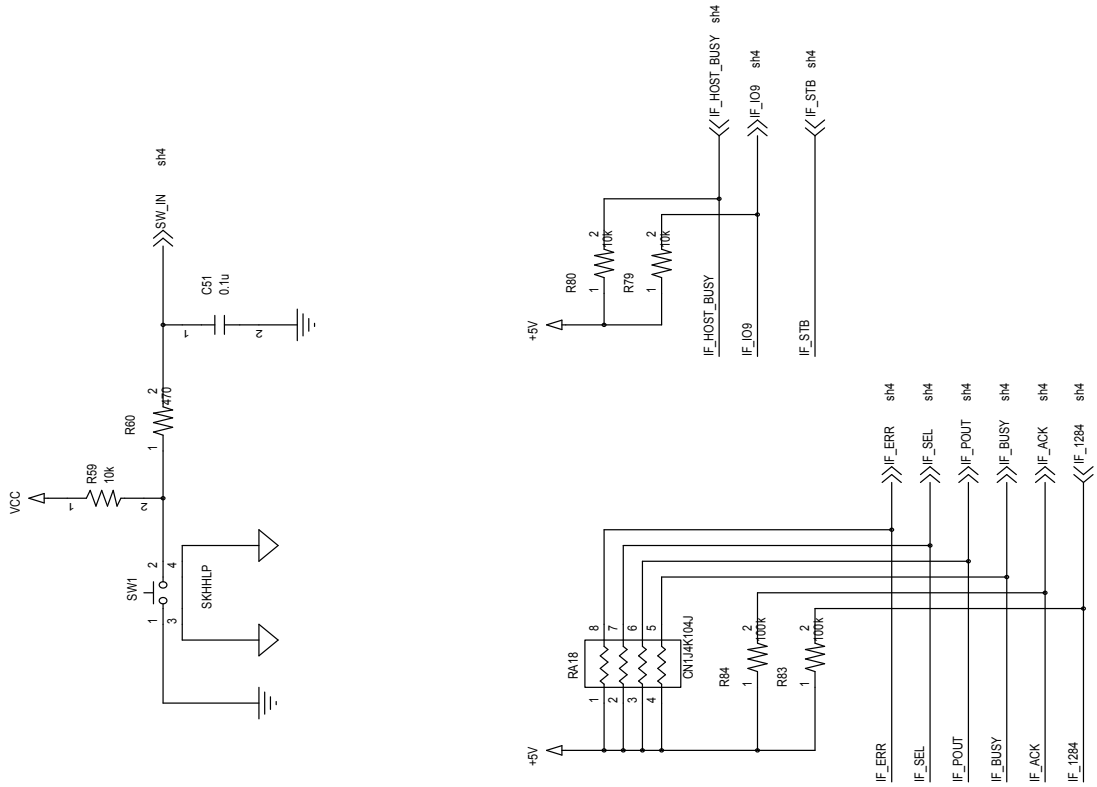

14-3. Parts List

Ethernet Interface Board

DRWG.NO.	REV.	PARTS NO.	PARTS NAME	Q' TY	REMARKS	RANK
C1		NPN	CERA.CAPA.CHIP1608 2.2UF 6.3V	1		
C2		NPN	CHEM.CAPA.CHIP 100UF 6.3V	1		
C3		NPN	CHEM.CAPA.CHIP 22UF 6.3V	1		
C4		NPN	CERA.CAPA.CHIP1608 470PF 50V	1		
C5		NPN	CERA.CAPA.CHIP1608 0.1UF 25V	1		
C6		NPN	CERA.CAPA.CHIP1608 1000PF 50V	1		
C7		NPN	CERA.CAPA.CHIP1608 0.022UF 50V	1		
C8-17		NPN	CERA.CAPA.CHIP1608 0.1UF 25V	10		
C18		NPN	CERA.CAPA.CHIP1608 470PF 50V	1		
C19-20		NPN	CERA.CAPA.CHIP 10PF 25V	2		
C21-23		NPN	CERA.CAPA.CHIP1608 470PF 50V	3		
C24-C25					NOT USED	
C26		NPN	CERA.CAPA.CHIP1608 0.1UF 25V	1		
C27					NOT USED	
C28-30		NPN	CERA.CAPA.CHIP1608 0.1UF 25V	3		
C31					NOT USED	
C32-35		NPN	CERA.CAPA.CHIP1608 0.1UF 25V	4		
C36					NOT USED	
C37-39		NPN	CERA.CAPA.CHIP1608 0.1UF 25V	3		
C40		NPN	CERA.CAPA.CHIP 10UF 6.3V	1		
C41-42		NPN	CERA.CAPA.CHIP1608 0.1UF 25V	2		
C43-44		NPN	CERA.CAPA.CHIP 10PF 25V	2		
C45-46		NPN	CERA.CAPA.CHIP1608 0.1UF 25V	2		
C47-C50					NOT USED	
C51		NPN	CERA.CAPA.CHIP1608 0.1UF 25V	1		
C52-53		NPN	CERA.CAPA.CHIP 10UF 25V	2		
C54					NOT USED	
RA1-RA17					NOT USED	
RA18		NPN	RESIS. ARRAY CHIP CN1JK104J	1		
RA19-24		NPN	RESIS. ARRAY CHIP MNR14J103*	6		
R1-3		NPN	CHIP RES1608 33 OHM 1/16W 5%	3		
R4		NPN	CHIP RESISTOR 470 OHM 1/16W	1		
R5-6					NOT MOUNTED	
R7		NPN	CHIP RESISTOR 470 OHM 1/16W	1		
R8-9					NOT MOUNTED	
R10		NPN	CHIP RES1608 33 OHM 1/16W 5%	1		
R11					NOT MOUNTED	
R12-13		NPN	CHIP RES1608 2.7 KOHM 1/16W 5%	2		
R14					NOT USED	
R15		NPN	CHIP RES1608 33 OHM 1/16W 5%	1		
R16-R28					NOT USED	
R29		NPN	CHIP RES1608 1.5 KOHM 1/16W 5%	1		
R30-R35					NOT USED	
R36		NPN	CHIP RESISTOR 1 K-OHM 1/16W	1		
R37		NPN	CHIP RESISTOR 470 OHM 1/16W	1		
R38		NPN	CHIP RESISTOR 10 K-OHM 1/16W	1		
R39		NPN	CHIP RES1608 33 OHM 1/16W 5%	1		
R40-41					NOT USED	
R42-43		NPN	CHIP RESISTOR 4.7 K-OHM 1/16W	2		
R44		NPN	CHIP RESISTOR 2.4 K-OHM 1/16W	1		
R45					NOT USED	
R46		NPN	CHIP RESISTOR 10 K-OHM 1/16W	1		

Ethernet Interface Board

DRWG.NO.	REV.	PARTS NO.	PARTS NAME	Q' TY	REMARKS	RANK
R47		NPN	CHIP RES1608 33 OHM 1/16W 5%	1		
R48		NPN	CHIP RESISTOR 10 K-OHM 1/16W	1		
R49		NPN	CHIP RES1608 33 OHM 1/16W 5%	1		
R50		NPN	CHIP RESISTOR 10 K-OHM 1/16W	1		
R51		NPN	CHIP RES1608 33 OHM 1/16W 5%	1		
R52		NPN	CHIP RESISTOR 10 K-OHM 1/16W	1		
R53		NPN	CHIP RES1608 33 OHM 1/16W 5%	1		
R54		NPN	CHIP RESISTORE 100 K-OHM 1/16W	1		
R55-57		NPN	CHIP RESISTORE 820 OHM 1/16W	3		
R58		NPN	CHIP RESISTOR 3.3 K-OHM 1/16W	1		
R59		NPN	CHIP RESISTOR 10 K-OHM 1/16W	1		
R60		NPN	CHIP RESISTOR 470 OHM 1/16W	1		
R61-R64					NOT USED	
R65-66		NPN	CHIP RESISTOR 15 K-OHM 1/16W	2		
R67-68					NOT USED	
R69		NPN	CHIP RESISTOR 15 K-OHM 1/16W	1		
R70		NPN	CHIP RESISTOR 22 K-OHM 1/16W	1		
R71-R76					NOT USED	
R77		NPN	CHIP RESISTOR 10 K-OHM 1/16W	1		
R78		NPN	CHIP RESISTOR 10 K-OHM 1/16W	1		
R79		NPN	CHIP RESISTOR 10 K-OHM 1/16W	1		
R80		NPN	CHIP RESISTOR 10 K-OHM 1/16W	1		
R81-R82					NOT USED	
R83-84		NPN	CHIP RESISTOR 100 K-OHM 1/16W	2		
R85-86		NPN	CHIP RESISTOR 49.9 OHM 1/10W	2		
R87		NPN	CHIP RES1608 33 OHM 1/16W 5%	1		
R88-89		NPN	CHIP RESISTOR 49.9 OHM 1/10W	2		
R90-R92					NOT USED	
R93		NPN	CHIP RES1608 33 OHM 1/16W 5%	1		
R94-R99					NOT USED	
R100		NPN	CHIP RESIS 6.49 K-OHM 1/16W 1%	1		
R101					NOT MOUNTED	
R102		NPN	CHIP RESISTOR 2.2 K-OHM 1/16W	1		
R103		NPN	CHIP RESISTOR 10 K-OHM 1/16W	1		
R104-R106					NOT USED	
R107-108		NPN	CHIP RESISTOR 15 K-OHM 1/16W	2		
R109-115					NOT USED	
R116					NOT MOUNTED	
R117-119		NPN	CHIP RESISTOR 10 K-OHM 1/16W	3		
R120		NPN	CHIP RESISTOR 100 OHM 1/16W	1		
R121		NPN	CHIP RESISTOR 4.7 K-OHM 1/16W	1		
R122		NPN	CHIP RESISTOR 0 OHM 1/16W	1		
R123					NOT MOUNTED	
R124		NPN	CHIP RESISTOR 0 OHM 1/16W	1		
R125		NPN	CHIP RESISTOR 10 K-OHM 1/16W	1		
R126		NPN	CHIP RESISTOR 0 OHM 1/16W	1		
R127		NPN	CHIP RESISTOR 10 K-OHM 1/16W	1		
R128					NOT MOUNTED	
R129		NPN	CHIP RESISTOR 0 OHM 1/16W	1		
R130					NOT MOUNTED	
R131		NPN	CHIP RES1608 33 OHM 1/16W 5%	1		
R132		NPN	CHIP RES1608 33 OHM 1/16W 5%	1		

Ethernet Interface Board

DRWG.NO.	REV.	PARTS NO.	PARTS NAME	Q' TY	REMARKS	RANK
R133-134					NOT MOUNTED	
D1					NOT USED	
D2		NPN	LED CHIP LT1D40A*	1		
D3		NPN	LED CHIP LT1E40A*	1		
D4-5		NPN	DIODE ARRAY MAX3208EAUB	2		
D6-7					NOT MOUNTED	
TR1		NPN	DIGITAL TRANSISTOR FN1A4P	1		
TR2		NPN	CHIP TRANSISTOR KTC3875S-G*AL	1		
U1		NPN	CPU NS7520B-1-C36	1		
U2		NPN	IC-REG L88M33T*TL	1		
U3		NPN	IC-REG S-1165B15*	1		
U4		NPN	IC-RESET S-80130CN*	1		
U5		NPN	FLASH MEMORY 29AL016D90TFI010	1		
U6		NPN	SDRAM MT48LC4M16A2P	1		
U7		NPN	CPLD EPM3128ATC100	1		
U8					NOT USED	
U9		NPN	PHY KSZ8721BL	1		
U10		NPN	CMOS 74ALVC2G04USE*	1		
U11		NPN	CMOS 74ALVC1G08*	1		
SW1		NPN	PUSH SWITCH SKHHLP	1		
CN1		NPN	CONNECTOR TM11R-5M2-88-LP	1		
CN2		NPN	CONNECTOR 52975-1883	1		
CN3					NOT USED	
CN4		NPN	CONNECTOR PHEC40P-R111LF	1		
X1		NPN	CRYSTAL NX5032 18.432MHZ	1		
X2		NPN	CRYSTAL NX5032 25.000MHZ	1		
JP1		NPN	CONNECTOR IMSA-9261B-2-06Y912	1		
		NPN	CONNECTOR IMSA9215H-GF	1		
FB1-3		NPN	CHIP BEADS IND. BK1608HS601*	3		
L1					NOT USED	
L2		NPN	PULSE FORMER H1260NLT	1		
L3-L5					NOT USED	
TP1-12					NOT USED	



**ELECTRONIC PRODUCTS DIVISION
STAR MICRONICS CO., LTD.**

536 Nanatsushinya, Shimizu-ku, Shizuoka,
424-0066 Japan
Tel: (int+81)-54-347-0112, Fax: (int+81)-54-347-0409

Please access the following URL
<http://www.star-m.jp/eng/dl/dl02.htm>
for the latest revision of the manual.

Distributed by

**OVERSEAS SUBSIDIARY COMPANIES
STAR MICRONICS AMERICA, INC.**

1150 King Georges Post Road, Edison, NJ 08837-3729 U.S.A.
Tel: (int+1)-732-623-5555, Fax: (int+1)-732-623-5590

STAR MICRONICS EUROPE LTD.

Star House, Peregrine Business Park, Gomm Road,
High Wycombe, Bucks, HP13 7DL, U.K.
Tel: (int+44)-1494-471111, Fax: (int+44)-1494-473333

STAR MICRONICS ASIA LTD.

Rm. 1901-5, 19/F., Enterprise Square Two,
3 Sheung Yuet Road, Kowloon Bay, Hong Kong
Tel: (int+852)-2796-2727, Fax: (int+852)-2799-9344